

Product Specification

SPECIFICATION FOR APPROVAL

- () Preliminary Specification
 () Final Specification

Title	7.0"W (480 X RGB X 234) TFT-LCD
--------------	--

BUYER	
MODEL	

SUPPLIER	LG.Philips LCD Co., Ltd.
MODEL	LT070W02
SUFFIX	* TMG2

***Without Tcon**

SIGNATURE	DATE
_____/	_____
_____/	_____
_____/	_____

APPROVED BY	DATE
C.S. KYOUNG /G.Manager	_____
REVIEWED BY	
S.D. JUNG /Manager	_____
PREPARED BY	
J.Y. KIM /Engineer	_____

**Product Engineering Dept.
LG. Philips LCD Co., Ltd**

Product Specification**CONTENTS**

NO.	ITEM	PAGE
0	Record of Revisions	3
1	Summary	4
2	Features	4
3	General Specification	4
4	Interface (Input Terminal)	5
5	Absolute Maximum Ratings	6
6	Electrical Characteristics	7
7	Electro-optical Characteristics	12
8	Mechanical Characteristics	15
9	Reliability Test	17
10	Packing	18
11	Precautions	19

Product Specification

1. Summary

The LT070W02-TMG2 is a **Board Assembly Product** of TFT LCD without any extra system.

This Board Assembly utilizes amorphous silicon thin film transistors and a 16:9 aspect ratio. A 7.0" active matrix liquid crystal display allows full color to be displayed.

The applications are Portable DVD, Multimedia applications and others AV system.

2. Features

- Utilizes a panel with a 16:9 aspect ratio, which makes the module suitable for use in wide-screen systems.
- The 7.0" screen produces a high resolution image that is composed of 112,320 pixel elements in a stripe arrangement.
- Wide viewing angle technology is employed.
[The most suitable viewing direction is in the 6 o'clock direction.]
- By adopting an active matrix drive, a picture with high contrast is realized.
- This Board Assembly is accomplished through the use of COG mounting technology.
- By adopting a high aperture panel, high transmittance color filter and high transmission polarizing plates, transmittance ratio is realized.

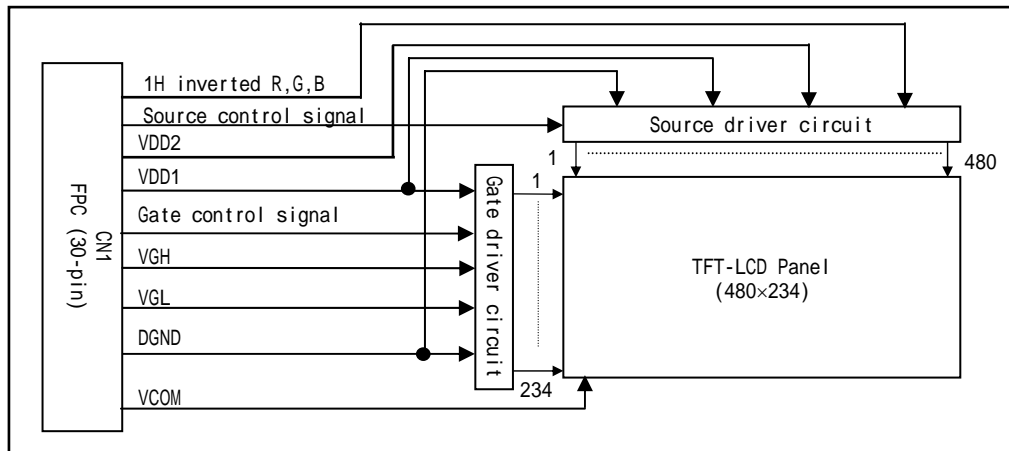

3. General Specification

CHARACTERISTIC ITEM	SPECIFICATION
Video Signal Interface	Analog Video Interface
Display Technology	a-Si TFT active matrix
Display Mode	TN Type Full Color / Transmitting Type / Normally White
Screen Size (Diagonal)	7.0" (17.78cm)
Outline Dimension	162.7mm (W) X 139.4mm (H) X 1.89mm (D)
Active Area	154.08mm (W) X 86.58mm (H)
Number Of dots	480(H) X 3(R,G,B) X 234(V)
Dot Pitch	0.107mm (W) X 0.370mm (H)
Color Filter Array	RGB vertical stripes
Weight	65 g (Max.)
Surface Treatment	Anti-Glare Treatment

Product Specification

4. Interface (Input terminal)

1> TFT-LCD Panel Driving Part

Pin No.	SYMBOL	FUNCTION	REMARK
1	GND	Ground for logic circuit	
2	VCC	Supply voltage of logic control circuit for scan driver	
3	VGL	Negative power for scan driver	
4	VGH	Positive power for scan driver	
5	STVR	Open	Forced Up to Down Sampling Mode
6	STVL	Vertical start pulse	
7	CLK	Shift clock input for scan driver	
8	U/D	Open	Forced Up to Down Sampling Mode
9	GOE	Output enable input for scan driver(GOE)	H: enable / L:disable
10	VCOM	Common electrode driving signal	
11	VCOM	Common electrode driving signal	
12	L/R	LEFT/RIGHT scan control input	See 6-3> P.9
13	MOD	Sequential sampling and simultaneous sampling setting	
14	SOE	Output enable input for data driver(INH)	
15	STHL	Start pulse for horizontal scan line	
16	STHR	Start pulse for horizontal scan line	
17	CPH3	Sampling and shifting clock pulse for data driver	
18	CPH2	Sampling and shifting clock pulse for data driver	
19	CPH1	Sampling and shifting clock pulse for data driver	
20	VCC	Supply voltage of logic control circuit for data driver	
21	GND	Ground for logic circuit	
22	VR	Alternated video signal input(Red)	
23	VG	Alternated video signal input(Green)	
24	VB	Alternated video signal input(Blue)	
25	AVDD	Supply voltage for analog circuit	
26	AVSS	Ground for analog circuit	

****The matching connector part number is GF053-26S-LSS(Bottom Contact Type) or GF055-26S-LSS (Top Contact Type) manufactured by LG Cable Ltd. or equivalent.**

Product Specification

5. Absolute Maximum Ratings

PARAMETER	SYMBOL	CONDITION	MIN.	MAX.	UNIT	REMARK
Logic Voltage	VDD1	$T_a=25$	-0.5	6.0	V	
Source Driver Voltage	VDD2	$T_a=25$	-0.5	6.0	V	
Digital Input Signals	V_{DI}	$T_a=25$	-0.5	VDD1+0.5	V	[Note 5-1]
Analog Input Signals	V_{AI}	$T_a=25$	-0.5	VDD2+0.5	V	[Note 5-2]
Gate Driver High Supply Voltage	VGH	$T_a=25$	-0.5	28	V	
Gate Driver Low Supply Voltage	VGL	$T_a=25$	-16	0.5	V	
Storage Temperature	T_{st}	-	-20	70		[Note 5-3,4]
Operating Temperature (Ambient Temperature)	T_a	-	-10	60		[Note 5-3,4,5,6]

[Note 5-1] STVL, CLK, STHL, MOD, L/R, SOE, CPH1, CPH2, CPH3, STHR

[Note 5-2] VR, VG, VB

[Note 5-3] This rating applies to all parts of the module and should not be exceeded.

[Note 5-4] Maximum wet-bulb temperature is 60 . Condensation of dew must be avoided as electrical current leaks will occur, causing a degradation of performance specifications.

[Note 5-5] The operating temperature only guarantees operation of the circuit. The contrast, response speed, and the other specification related to electro-optical display quality is determined at the room temperature, $T_a = 25$.

[Note 5-6] Ambient temperature when the backlight is lit (reference value).

Product Specification

6. Electrical Characteristics

1> Recommended Operating Conditions

TFT-LCD Panel Driving Section

$T_a=25$

PARAMETER		SYMBOL	MIN.	TYP.	MAX.	UNIT	REMARK
Logic Supply Voltage		VDD1	3.0	5.0	5.2	V	
Digital Input Signal	High Level	V_{IH}	0.8VDD1	-	VDD1	V	
	Low Level	V_{IL}	0	-	0.2VDD1	V	
Source Driver Supply Voltage		VDD2	4.5	5.0	5.5	V	
Gate Driver	High Supply Voltage	VGH	16.0	16.5	17.0	V	
	Low Supply Voltage	VGL	-5.5	-5	-4.5	V	
Analog Video Signal Input Voltage		V_{VI}	AGND+1.0	-	VDD2-1.0	V	
Color Filter Substrate Voltage	AC Component	$V_{COM_{AC}}$	4.0	5.0	6.0	V_{P-P}	
	DC Component	$V_{COM_{DC}}$	1.5	1.75	2.0	V	[Note 1]

[Note 1] This value should be tuned for optimal display quality of each panel.

***** Cautionary Matter : When applying or disconnecting power, please be sure that such action is sequentially carried out for all power supplies. In addition, apply input signals only after power has been turned on.

-Source Driver :

Turn on power to VDD1 and VDD2 in this order.
Turn off power in the reverse order.

-Gate Driver :

Turn on power to VDD1, VGL and VGH in this order.
Turn off power in the reverse order.

Product Specification

PARAMETER	SYMBOL	MIN.	TYP.	MAX.	UNIT	REMARK
Logic Supply Current	I_{DD1}	-	-	5.0	mA	VDD1 = 5.0V
Source Driver Supply Current	I_{DD2}	-	-	50	mA	VDD2 = 5.0V
Gate Driver High Supply Current	I_{GH}	-	-	0.5	mA	VGH=16.5V
Gate Driver Low Supply Current	I_{GL}	-	-	15	mArms	VGL _{DC} =-10V

Product Specification

2> Timing Characteristics of input signals

	PARAMETER	SYMBOL	MIN.	TYP.	MAX.	UNIT	REMARK
S O U R C E	Clock cycle time	Tcph	100	-	2000	ns	CPHn
	CPHn pulse duty	Tcwh	40	-	60	%	CPHn
	CPHn phase delay	Tc12 Tc23 Tc31	20	-	Tcph/2	ns	CPH1-CPH2 CPH2-CPH3 CPH3-CPH1
	Set-up time of analog signals	Tasu	60	-	-	ns	VA,VB,VC-CPHn
	Hold time of analog signals	Tahd	40	-	-	ns	CPHn-VA,VB,VC
	STHn set-up time	Tsu	20	-	-	ns	STHn-CPHn
	STHn hold time	Thd	10	-	-	ns	CPHn-STHn
	Propagation delay of STHn	Tphl	10	35	50	ns	CL=25pF
	Sample and hold disable time	Tdis	8	-	-	us	OE-STHn
	SOE pulse width	Twoe	1	-	-	Tcph	
G A T E	Clock Frequency	f _{CL}	-	-	500	KHz	
	Clock Pulse Width	T _{CWH} T _{CWL}	500 500	- -	- -	ns	
	OE Disable Time	T _{WOEB}	1000	-	-	ns	
	STV Setup Time	T _{SUSTV}	200	-	-	ns	
	STV Hold Time	T _{HDSTV}	200	-	-	ns	
	Output Delay to CL	T _{pd1r}	-	-	800	ns	CL=300pF
	Output Delay to CL	T _{pd1f}	-	-	800	ns	CL=300pF
	Output Delay to OE	T _{pd2r} T _{pd2f}	- -	- -	800 800	ns	CL=300pF

3> Scanning Mode Selection (Reference position : @ Input terminal)

MODE	L/R	U/D	STHL	STHR	STV	REMARK
Normal Mode	H	H	Signal Output	Signal Input	Input	See P.15 (the figure of [Note 7-3])
Left/Right Reverse Mode	L	H	Signal Input	Signal Output	Input	

***** H(High Level) =VDD1 , L(Low Level)=DGND

Product Specification

Timing for a Source Driver

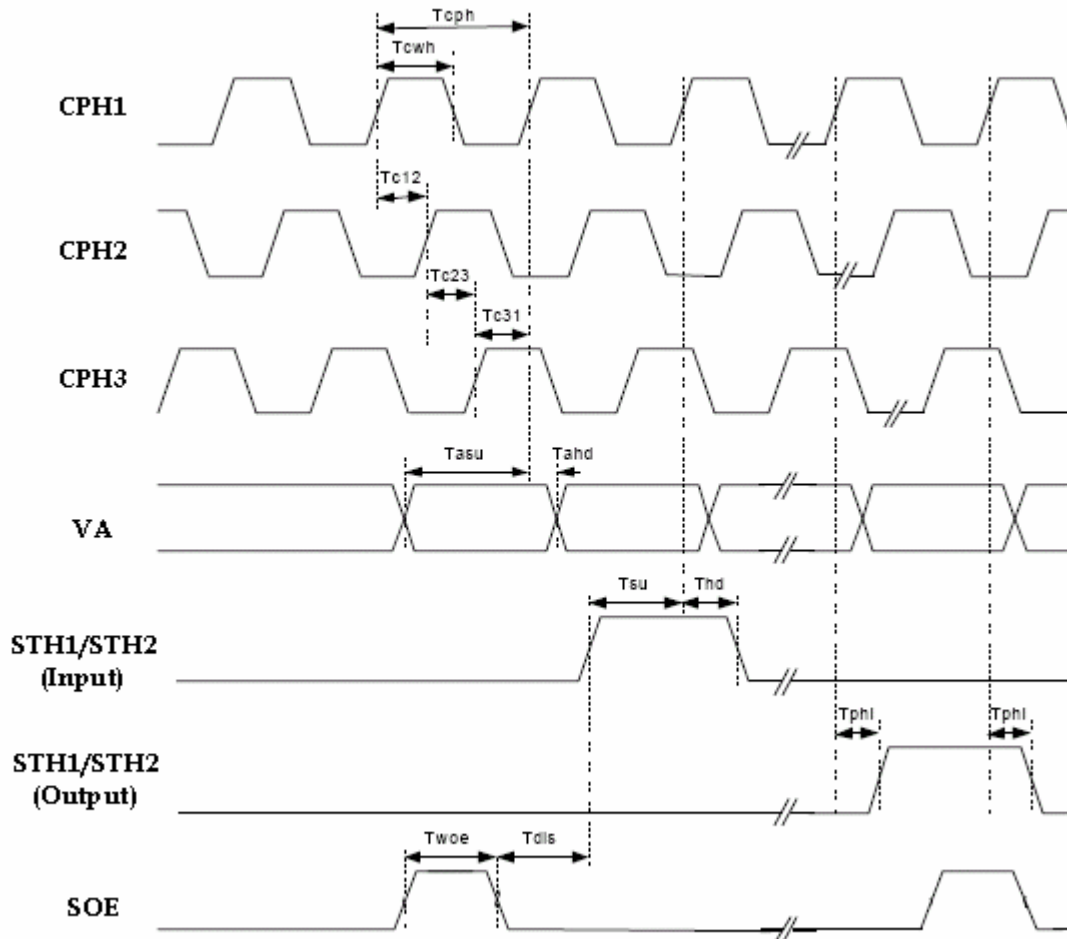

• Remark : The sample-and-hold circuits are switched and the outputs are started with new data at the rising edge of SOE.

“ For T_{woe} period, shift register in source driver are reset internally.”

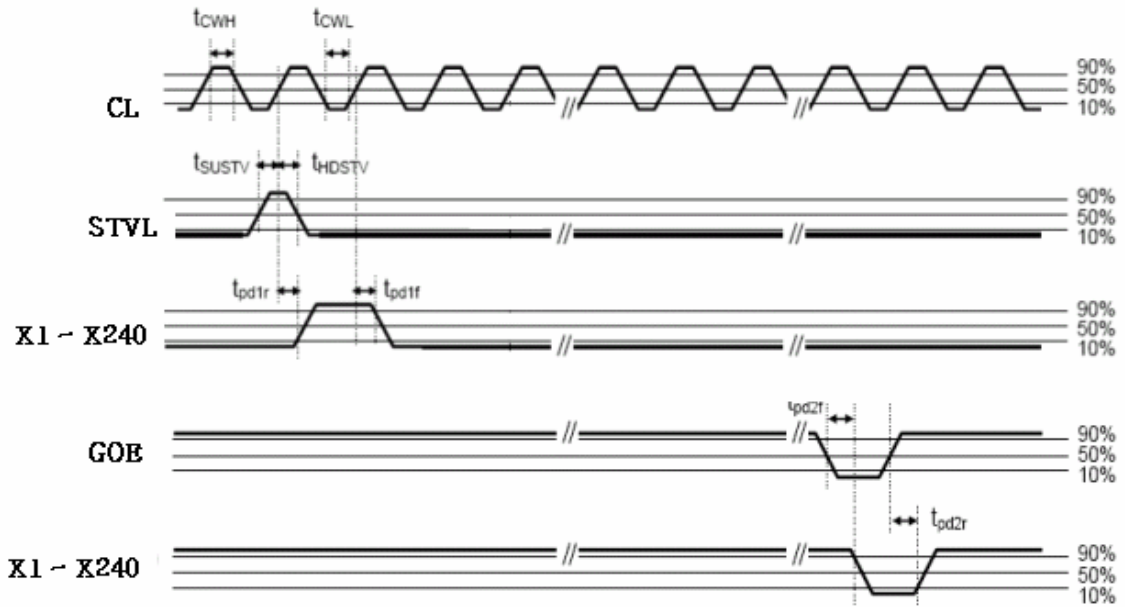
Product Specification
Switching Characteristics Waveform for Gate Driver

Product Specification

7. Electro-optical Characteristics

 $T_a=25$

PARAMETER		SYMBOL	CONDITION	MIN.	TYP.	MAX.	UNIT	REMARK
Transmittance		T	-	(5.0)	(5.8)	-	%	
Contrast Ratio		CR	Optimal	300	400	-	-	[Note 7-2]
White Color Chromaticity		W_x	-	0.283	0.313	0.343	-	[Note 7-1]
		W_y		0.299	0.329	0.359	-	
Viewing Angle	$\phi=180^\circ$	l	CR 10	60	65	-	°	[Note 7-2] [Note 7-3]
	$\phi=0^\circ$	r		60	65	-	°	
	$\phi=90^\circ$	u		40	45	-	°	
	$\phi=270^\circ$	d		50	55	-	°	
Response Time	Rise	r	=0°	-	10	20	ms	[Note 7-4]
	Fall	d		-	20	30	ms	

** All transmissive mode optical characteristics are measured under back light condition. but, following conditions are just "Internal Conditions for Quality Test" of LG.Philips LCD.

< Reference Backlight Unit >

ITEM	SYMBOL	MIN.	TYP.	MAX.	UNIT	REMARK
Luminance	B_1	-	6300	-	cd/m ²	Center Point
White Color Chromaticity	X	0.281	0.296	0.311	-	Center Point
	Y	0.278	0.293	0.308		Center Point

Product Specification

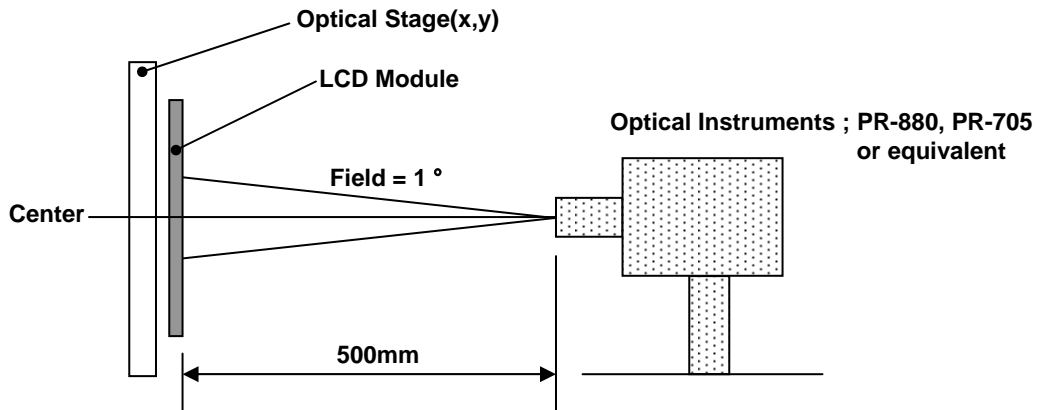

Measuring Condition ;

-Measuring surroundings : Dark Room

-Measuring temperature : $T_a=25$

-Adjust operating voltage to get optimum contrast at the center of the display.

-Measured value at the center point of LCD panel after more than 30 minutes while backlight turning on.

[Note 7-1] Measured on the center area of the panel by PHOTO RESEARCH photometer PR-880.

[Note 7-2] Contrast ratio is defined as follows ;

$$\text{Contrast Ratio(CR)} = \frac{\text{Photo detector output with LCD being "white"}}{\text{Photo detector output with LCD being "black"}}$$

[Note 7-3] Viewing angle range is defined as follows;

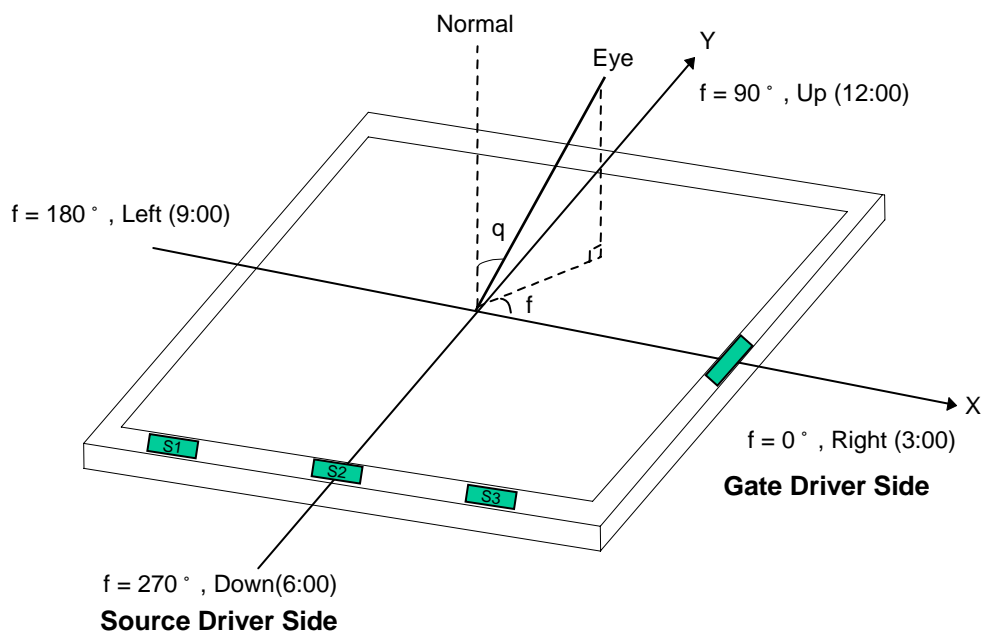

Product Specification

[Note 7-4]

Response time is obtained by measuring the transition time of photo detector output, when input signals are applied so as to make the area “black” to and from “white”.

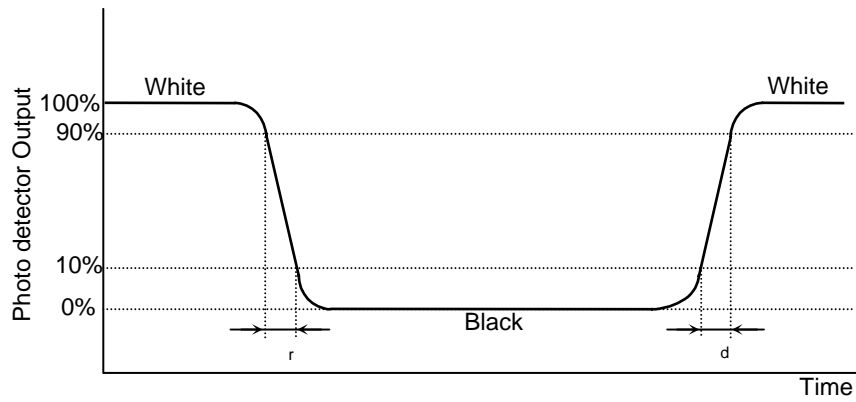

Product Specification

8. Mechanical Characteristics

PARAMETER	SPECIFICATION		UNIT	REMARK
Outline Dimension	Width	162.7	mm	
	Height	139.4	mm	
	Depth	1.89 (TYP)	mm	
Active Display Area	Width	154.08	mm	
	Height	86.58	mm	
Weight	65 (Max.)		g	
Surface Treatment	Anti-Glare Treatment		-	

Product Specification

[Outline Dimension]

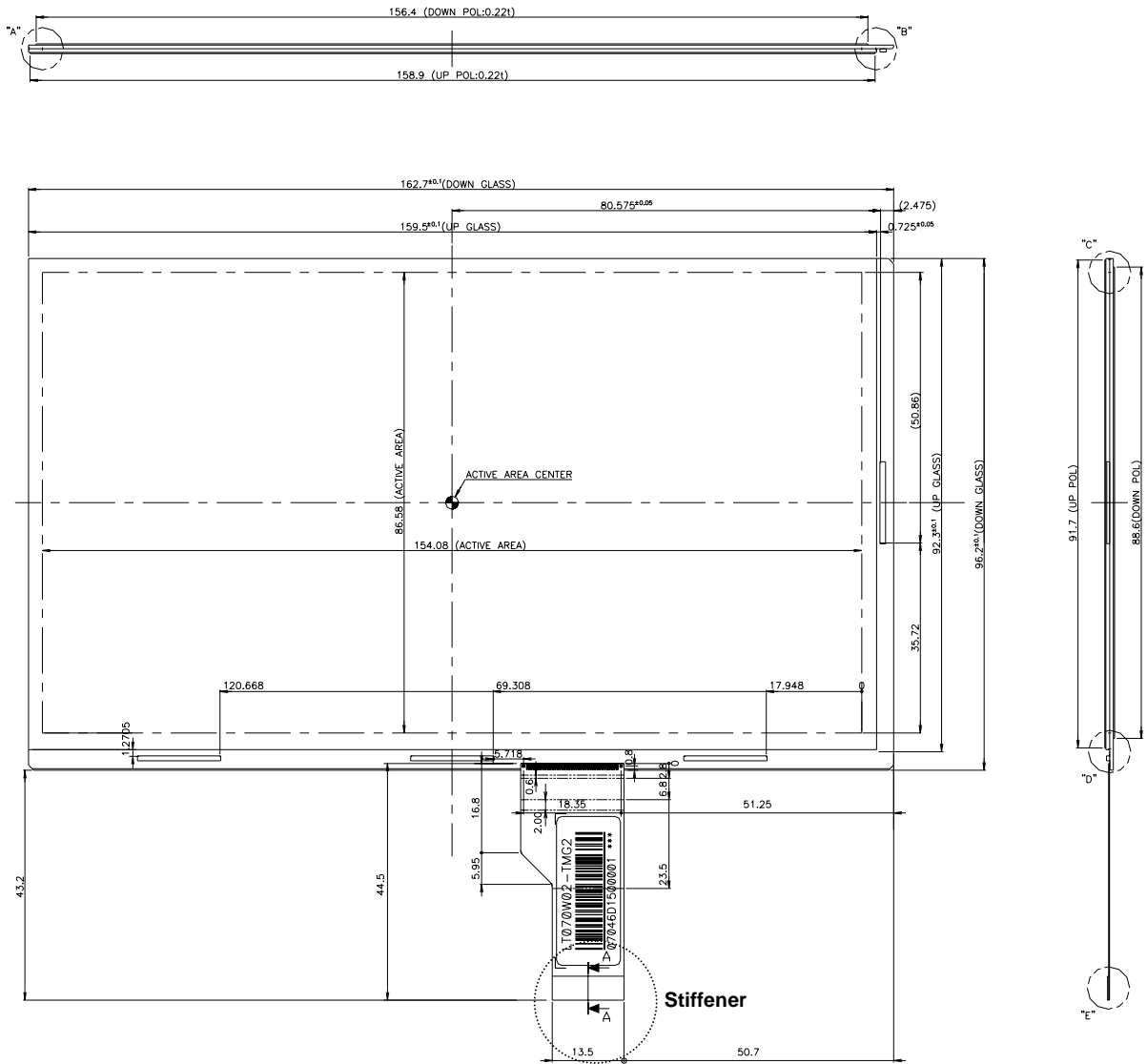

DETAIL "A" (SCALE 5:1)

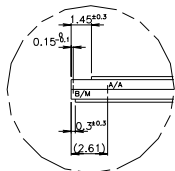

DETAIL "C" (SCALE 5:1)

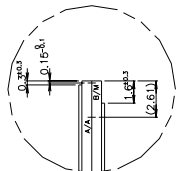

DETAIL "B" (SCALE 5:1)

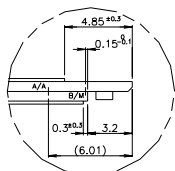

DETAIL "D" (SCALE 5:1)

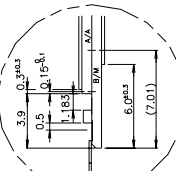

* SEC. E (SCALE 10:1)

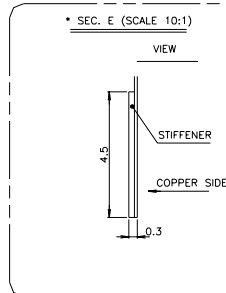

* DETAIL COPPER SIDE (SCALE 5:1)

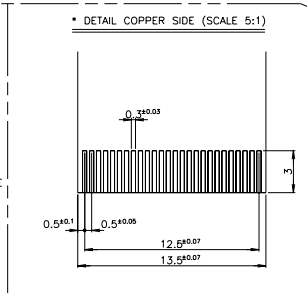

Product Specification

9. Reliability Test

No.	Test Items	Test Condition	REMARK
1	High Temperature Storage Test	T _a =70 240h	[Note 9-1,2,3]
2	Low Temperature Storage Test	T _a =-20 240h	[Note 9-1,2,3]
3	High Temperature Operation Test	T _a =60 240h	[Note 9-1,2,3]
4	Low Temperature Operation Test	T _a =-10 240h	[Note 9-1,2,3]
5	High Temperature and High Humidity Operation Test	T _a =50 80%RH 240h	[Note 9-1,2,3]
6	Thermal Shock Test	-10 (0.5h) ~ 60 (0.5h) / 100 cycles	

[Note 9-1] T_a = Ambient Temperature

[Note 9-2] In the Reliability Test, Confirm performance after leaving in room temp.

[Note 9-3] In the standard condition, there shall be no practical problems that may affect the display function.

Product Specification

10. Packing

10-1. Designation of Lot Mark

a) Lot Mark

A	B	C	D	E	F	G	H	I	J	K	L	M
---	---	---	---	---	---	---	---	---	---	---	---	---

A,B,C : SIZE(INCH)
 E : MONTH

D : YEAR
 F ~ M : SERIAL NO.

Note

1. YEAR

Year	2001	2002	2003	2004	2005	2006	2007	2008	2009	2010
Mark	1	2	3	4	5	6	7	8	9	0

2. MONTH

Month	Jan	Feb	Mar	Apr	May	Jun	Jul	Aug	Sep	Oct	Nov	Dec
Mark	1	2	3	4	5	6	7	8	9	A	B	C

b) Location of Lot Mark

Serial No. is printed on the label. The label is attached to the backside of the LCD module.

10-2. Packing Form

a) Package quantity in one box : 80 pcs

b) Box Size(mm) : 384(L)×334(W)×191(H)

Product Specification

11. PRECAUTIONS

Please pay attention to the following when you use this TFT LCD COG Assembly(Board Ass'y).

11-1. MOUNTING PRECAUTIONS

- (1) You must mount a Board Ass'y using packing trays arranged.
And do not hold on to the FPC while carrying.
- (2) You should consider the mounting structure so that uneven force(ex. Twisted stress) is not applied to the Board Ass'y.
And the case on which a Board Ass'y is mounted should have sufficient strength so that external force is not transmitted directly to the Board Ass'y.
- (3) Please attach a transparent protective plate to the surface in order to protect the polarizer.
Transparent protective plate should have sufficient strength in order to resist external force.
- (4) You should adopt radiation structure to satisfy the temperature specification.
- (5) Acetic acid type and chlorine type materials for the cover case are not describe because the former generates corrosive gas of attacking the polarizer at high temperature and the latter causes circuit break by electro-chemical reaction.
- (6) Do not touch, push or rub the exposed polarizers with glass, tweezers or anything harder than HB pencil lead. And please do not rub with dust clothes with chemical treatment.
Do not touch the surface of polarizer for bare hand or greasy cloth.(Some cosmetics are determined to the polarizer.)
- (7) When the surface becomes dusty, please wipe gently with absorbent cotton or other soft materials like chamois soaks with petroleum benzene. Normal-hexane is recommended for cleaning the adhesives used to attach front / rear polarizers. Do not use acetone, toluene and alcohol because they cause chemical damage to the polarizer.
- (8) Wipe off saliva or water drops as soon as possible. Their long time contact with polarizer causes deformations and color fading.
- (9) Do not open the case because inside circuits do not have sufficient strength.

11-2. OPERATING PRECAUTIONS

- (1) The spike noise causes the mis-operation of circuits. It should be lower than following voltage :
 $V = \pm 200\text{mV}$ (Over and under shoot voltage)
- (2) Response time depends on the temperature.(In lower temperature, it becomes longer.)
- (3) Be careful for condensation at sudden temperature change. Condensation makes damage to polarizer or electrical contacted parts. And after fading condensation, smear or spot will occur.
- (4) When fixed patterns are displayed for a long time, remnant image is likely to occur.
- (5) Sufficient suppression to the electromagnetic interference shall be done by system manufacturers.
Grounding and shielding methods may be important to minimize the interference.

Product Specification

12-3. ELECTROSTATIC DISCHARGE CONTROL

Since a module is composed of electronic circuits, it is not strong to electrostatic discharge. Make certain that treatment persons are connected to ground through wrist band etc. And don't touch interface pin directly.

12-4. PRECAUTIONS FOR STRONG LIGHT EXPOSURE

Strong light exposure causes degradation of polarizer and color filter.

12-5. STORAGE

When storing modules as spares for a long time, the following precautions are necessary.

- (1) Store them in a dark place. Do not expose the module to sunlight or fluorescent light. Keep the temperature between 5°C and 35°C at normal humidity.
- (2) The polarizer surface should not come in contact with any other object.
It is recommended that they be stored in the container in which they were shipped.

12-6. HANDLING PRECAUTIONS FOR PROTECTION FILM

- (1) When the protection film is peeled off, static electricity is generated between the film and polarizer.
This should be peeled off slowly and carefully by people who are electrically grounded and with well ion-blown equipment or in such a condition, etc.
- (2) The protection film is attached to the polarizer with a small amount of glue. If some stress is applied to rub the protection film against the polarizer during the time you peel off the film, the glue is apt to remain on the polarizer.
Please carefully peel off the protection film without rubbing it against the polarizer.
- (3) When the module with protection film attached is stored for a long time, sometimes there remains a very small amount of glue still on the polarizer after the protection film is peeled off.
- (4) You can remove the glue easily. When the glue remains on the polarizer surface or its vestige is recognized, please wipe them off with absorbent cotton waste or other soft material like chamois soaked with normal-hexane.