

celitron

WE THINK GREEN!

September
2022



celitron

WE THINK GREEN!



WHO WE ARE?

CELITRON DEVELOPS & MANUFACTURES ADVANCED ECO, BIO CONVERSION & STERILIZATION SOLUTIONS

MEDICAL SOLUTIONS

AGRICULTURAL SOLUTIONS

Hungarian company, established in 2005

7 Agricultural rendering solutions

600+ medical waste units deployed

Produced more than 4,500 sterilizers

Over 80 full time employees

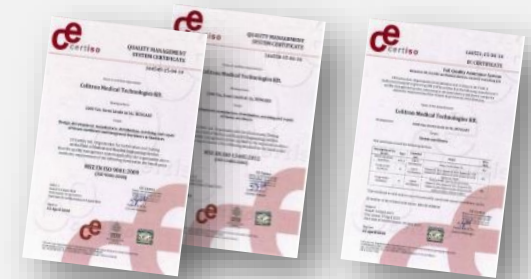

celitron

WE THINK GREEN!

CELITRON DEVELOPS innovative solutions for the Agricultural & Medical sectors



Patented Technology

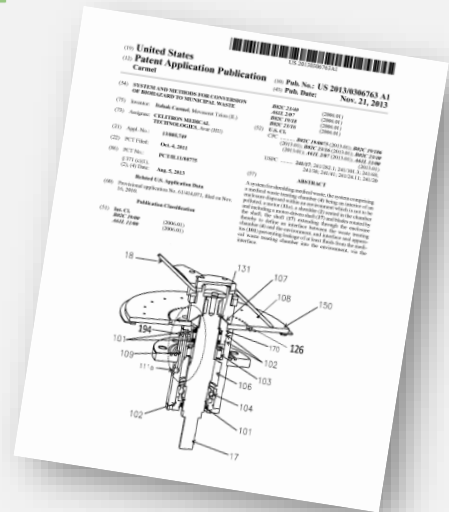

Compliance with the highest international standards
(PED, MDD, ISO 13485:2012, ISO 9001:2008, CE, EN 13060, EN 285, ASME, UL etc.)

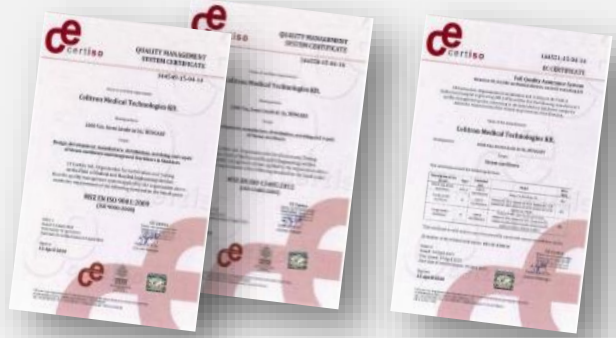

OEM for Leading Brands

USA, Switzerland, Germany, Portugal, Italy, Mexico



High innovative drive, R&D focused



WE THINK GREEN!



GLOBAL PRESENCE - MORE THAN 70 COUNTRIES



- | | | | | | |
|----------------|-----------|-------------|-------------|--------------|--------------|
| Afghanistan | Denmark | Iran | Malaysia | Norway | Slovakia |
| Albania | Ecuador | Iraq | Mauritania | Pakistan | Slovenia |
| Algeria | Egypt | Ireland | Mexico | Paraguay | South Africa |
| Angola | Estonia | Ivory Coast | Moldova | Peru | Syria |
| Australia | Finland | Jordan | Morocco | Philippines | Thailand |
| Azerbaijan | France | Kenya | Mozambique | Poland | Tunisia |
| Brazil | Georgia | Kuwait | Myanmar | Qatar | Turkey |
| Bulgaria | Ghana | Latvia | Namibia | Romania | Turkmenistan |
| Chile | Greece | Lebanon | Nepal | Russian Fed. | UAE |
| Colombia | Hungary | Libya | New Zealand | Rwanda | U.K |
| Costa Rica | India | Lithuania | Nicaragua | Saudi Arabia | Vietnam |
| Czech Republic | Indonesia | Macedonia | Nigeria | Serbia | Yemen |

CELITRON SOLUTIONS
FOR
DIFFERENT MARKETS

Agricultural Solutions

- ISS AGRI: waste conversion into high quality of protein and fat



Medical Solutions

- Medical Waste Treatment units (ISS)
- Steam Sterilizers



**CELITRON
ISS AGRI SOLUTION**

ADVANTAGES

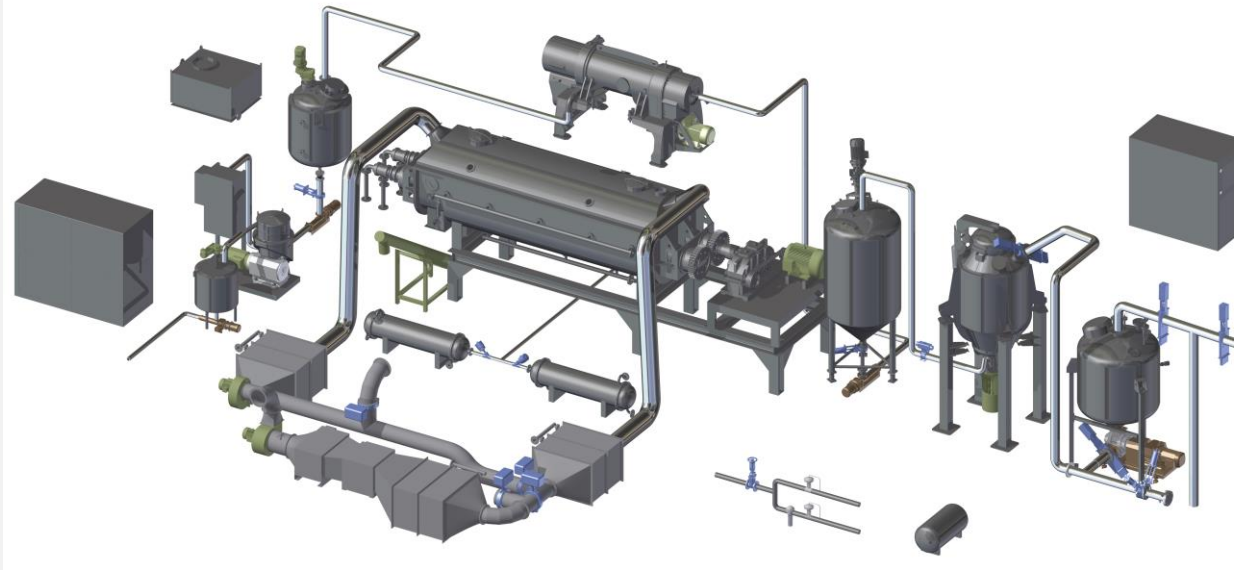

- Local and immediate conversion – to high quality oil & protein
- Lower energy consumption as a result of the shorter cycle time and the use of a pressure vessel
- Patented medical sterilization and shredding technology to prevent any possible contamination risk
- Small footprint of the systems
- Generating better quality meal and oil as a result of the immediate and short processing time of "fresh" material
- No odour risk
- No transportation





NEW RENDERING PROCESS AGRICULTURAL SOLUTIONS



Fixed solutions

- Chicken slaughterhouses
- Cattle slaughterhouses
- All types of waste including feathers and blood
- Insects protein processing - BSF



Mobile Solutions

- 7,500 birds per hour or other types of carcasses.
- Replace incinerators



CELITRON MEDICAL SOLUTIONS

CONVERTING MEDICAL WASTE INTO MUNICIPAL WASTE

- **Automatic, on-site treatment**
- **Used by: Hospitals, Clinics, Dialysis centers and Laboratories**
- **Capacity: 5-150 kg/h**
- **Treats: sharps, syringes, dialyzers, scalpels, small textiles, tests, papers, glass and plastic, etc..**
- **Uses our patented technology**
- **Treated waste is sterile can be handle as a municipal waste**



CELITRON MEDICAL SOLUTIONS

Steam sterilizers in compliance with the highest international standards

■ Steam Sterilizers

For hospital CSSD's, dental offices and private clinics

- *Small steam sterilizers: with 25 liters capacity*
- *Medium steam sterilizers: 90 – 200 liters*
- *Large steam sterilizers: 110 – 880 liters*



OUR MISSION - Green solution satisfied the need



- **Develop innovative rendering solution for the agricultural sector**
- **Large capacity on- site solutions for medical waste disposal**
- **More reliable Celitron steam sterilizers all around the world**



Celitron Medical Technologies Kft.
Szent László str. 36.
2600 Vác, Hungary



Internet
www.celitron.com



E-mail
info@celitron.com

