



A TRADITION OF QUALITY SINCE 1966



**PREMIUM**  
DIAMOND AND CBN WHEELS

## Dear Clients,

**PrJSC “POLTAVA DIAMOND TOOLS”** has been manufacturing top-quality diamond tools for the machine building, glass, electronic and woodworking industries since 1966. It is committed to constantly improving production quality and has been certified in accordance with ISO9001:2008, EN13236.

We offer **PREMIUM** product line.

**PREMIUM** — our newest line of diamond and CBN wheels:



- specially designed to compete with top international brands for use on CNC machines but at substantially lower prices, used in machine building, woodworking and metallurgy;
- the production and sharpening of circular and band saws, metal cutting and special tools, as well as machine building parts.

Our specialists have a wealth of experience in the production and use of diamond wheels and tools, and PrJSC “POLTAVA DIAMOND TOOLS” is always pleased to offer you our technical support and assistance in choosing diamond wheels and tools.

**WE LOOK FORWARD TO WORKING WITH YOU!**

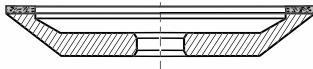
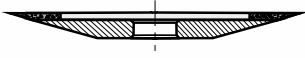
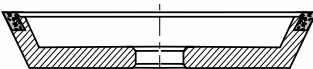
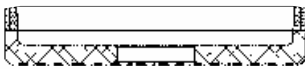
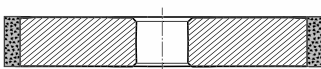
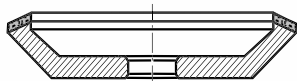
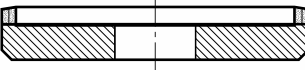
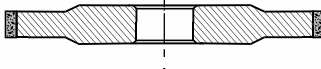
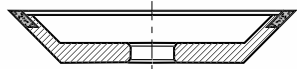
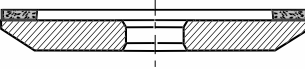

# CONTENTS

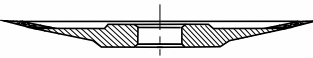
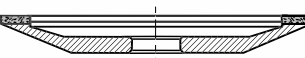
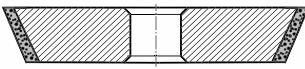
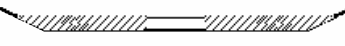
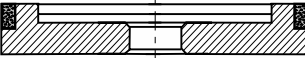
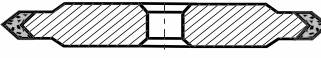
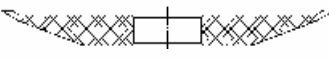
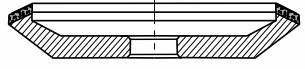
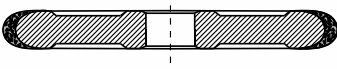
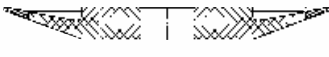
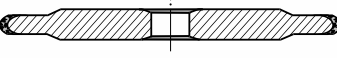
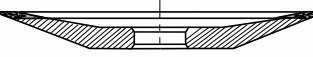
Item	p.	Item	p.	Item	p.
<b>General information</b>	4	<b>12A2-45</b> Cup grinding wheels 	20	<b>4B2</b> Dish grinding wheels 	24
<b>Grinding machine types and wheels</b>	12	<b>11V9-70</b> Cup grinding wheels 	20	<b>6A2</b> Flat recessed grinding wheels 	25
<b>1A1</b> Straight grinding wheels 	16	<b>12V5-45</b> Cup grinding wheels 	21	<b>12M2-45</b> Grinding wheels 	25
<b>14A1</b> Straight grinding wheels 	17	<b>12V9-45</b> Cup grinding wheels 	21	<b>4A2</b> Dish grinding wheels 	26
<b>1A1R</b> Cut-off wheels 	17	<b>12V9-20</b> Dish grinding wheels 	22	<b>12A2-20</b> Dish grinding wheels 	26
<b>1V1</b> Grinding wheels (special) 	18	<b>12V9-25</b> Dish grinding wheels 	22	<b>6A9</b> Recessed flat grinding wheels 	27
<b>14EE1</b> Flat grinding wheels with double-sided conical profile 	18	<b>4V2</b> Dish grinding wheels 	23	<b>12V5-20</b> Dish grinding wheels 	27
<b>1FF1</b> Flat grinding wheels with semicircular convex profile 	19	<b>4BT9</b> Dish grinding wheels 	23	<b>Wheels shapes in our product line</b>	28
<b>14FF1</b> Grinding wheels with semicircular convex profile 	19	<b>12R4</b> Dish grinding wheels 	24	<b>QUESTIONNAIRE for selecting PREMIUM</b>	29

**PrJSC "POLTAVA DIAMOND TOOLS"** produces a wide range of diamond and CBN wheels and tools used for:

- producing and sharpening of tungsten carbide and high-speed steel tools;
- grinding and polishing of tungsten carbide, heat-resistant, alloy-treated and stainless steels, glass, ceramics, silicon, refractories, gem stones and other materials;
- cutting of tungsten carbide, glass, marble, granite, quartz, and ceramics;
- drilling (boring) of glass.

Since 1966 the plant has been manufacturing top-quality diamond tools for the machine building, glass, electronic, and woodworking industries. It is committed to constantly improving production quality and has been certified in accordance with ISO 9001:2008, EN13236.

## APPLICATIONS FOR PREMIUM WHEELS

**Diamond and CBN grinding wheels for the production and sharpening of metal cutting tools and special tools:**

Grinding operations	Wheel type
Grinding of chip grooves	1A1, 14A1, 1V1, 1FF1, 14FF1
Flute grinding	1A1, 1V1, 12V9-45, 11V9-70
Clearance angle and face grinding	11V9-70, 12A2-20, 12V9-45, 6A9

**Manufacturing of machine-building parts:**

Grinding operations	Wheel type
Surface grinding	1A1, 14A1, 12A2-45
Cylindrical grinding	1A1, 1FF1
Centerless grinding	1A1

**Diamond and CBN grinding wheels for the production and sharpening of band and circular saws made of HSS and with tungsten carbide teeth:**

Grinding operations	Wheel type
Face grinding	12V9-20, 12V9-25, 4V2, 12R4, 12A2-20, 4BT9
Side grinding	1A1, 3A1
Top grinding	12A2-20, 4A2, 12V9-45, 12M2-45, 6A2

Our up-to-date manufacturing capabilities and complete production cycle, together with our advanced technology, top-grade materials and highly experienced specialists, allow us to produce wheels with standard dimensions as well as custom wheels made to individual client specifications.

## APPLICATION OF DIAMOND TOOLS AND THEIR ADVANTAGES OVER ABRASIVE TOOLS

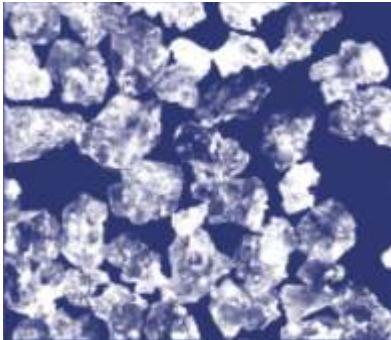

### Applications of diamond tools:

- machining, sharpening and finishing of tools made of all alloy types;
- sharpening and finishing of carbide tools;
- machining and cutting of silicon, germanium and other semiconducting materials;
- machining, cutting and finishing of tools made of ferrite, ceramic and glass materials;
- machining of graphite and carbon reinforced plastics;
- machining and cutting of reinforced fiber glass plastics, fiberplastics;
- finishing and polishing of precious stones;
- cutting, finishing and polishing of artificial and natural stones;
- machining of all types of decorative and technical glasses and porcelain;
- cutting and processing of all types of refractory materials.

### Applications of CBN tools

- finish grinding and sharpening of tools made of tungsten-molybdenum (P6M5) and other high-speed steels, particularly high-speed steels alloyed with vanadium and cobalt;
- finish and final grinding of high-precision parts made of heat resistant, stainless and high-alloy steel with high hardness (HRC55 and more) when high precision is required.

### Advantages of diamond and CBN grinding tools over abrasive tools:

- high wear resistance;
- workpiece life longer after diamond tool profiling;
- less thermal workpiece damage due to lower temperature in grinding zone;
- longer lasting, hence reduced changeover times;
- higher volumes at the same level of quality.

## PHYSICOMECHANICAL CHARACTERISTICS OF ABRASIVE TOOL MATERIALS

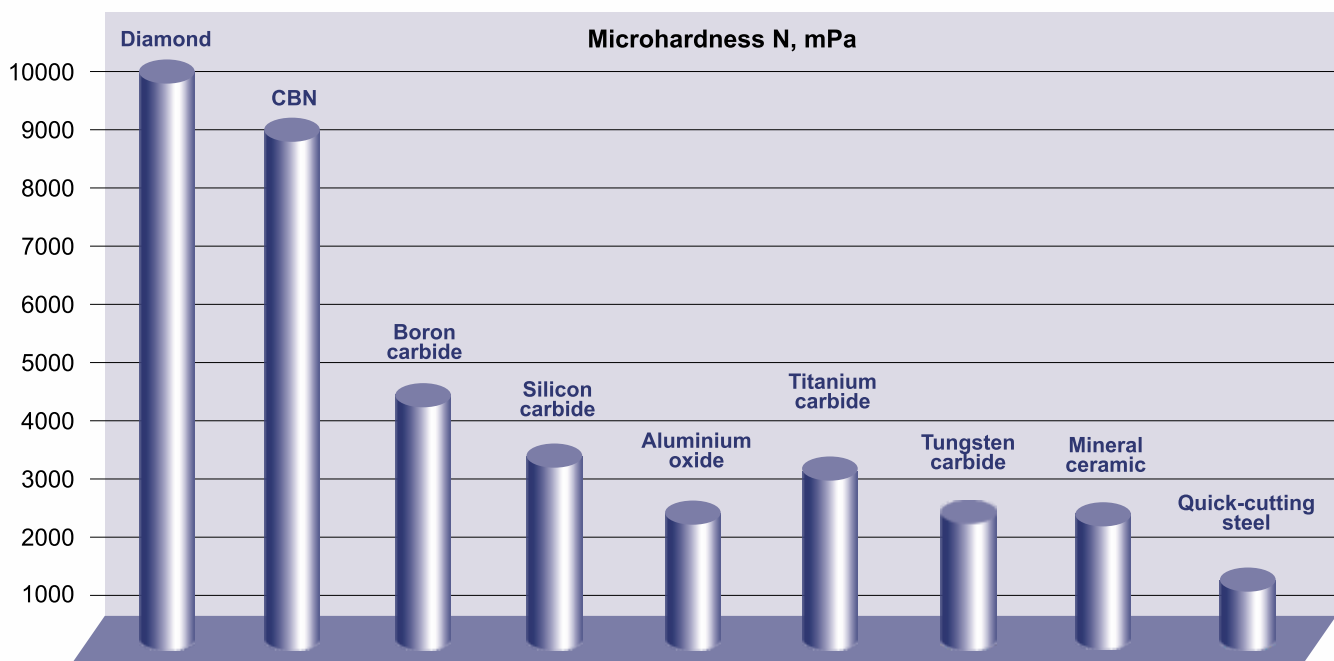

## International Grit Size Standards and their applications by operation

Type of operation	FEPA International Standard	International Standard ISO 565, $\mu\text{m}$	U.S. Standard ANSI B 74.16 mesh	Ukrainian Standard DSTU 3292-95 $\mu\text{m}$
Rough Grinding	D426 D301 D251 D213 D151	425/355 300/250 250/212 212/180 150/125	40/45 50/60 60/70 70/80 100/120	400/315 315/250 250/200 200/160 160/125
Finish Grinding	D126 D107	125/106 106/90	120/140 140/170	125/100 100/80
Fine Grinding	D91 D76 D64 D54 D46	90/75 75/63 63/53 53/45 45/38	170/200 200/230 230/270 270/325 325/400	80/63 63/50 50/40
Fine grinding, Polishing	M63 M40 M25 M20 M16 M10 M6.3 M4.0		500 550 650 1100 1500 1700 3000 4000	60/40 40/28 28/20 20/14 14/10 10/7 7/5 5/3

## Choice of grit sizes for wheels used to grind and sharpen tungsten carbide

Type of Bond	Recommended range of grit sizes	Roughness of workpiece surface, $R_a$ , $\mu\text{m}$		
		For face grinding and sharpening	For flat grinding	For circular grinding
Resin	D213 – D107	,08 – 0,16	,01 – 0,32	1,0 – 0,32
	D91 – D46	0,32 – 0,16	0,63 – 0,20	0,63 – 0,20
Resin (coated diamond)	D126 – D46	0,32 – 0,10	,08 – 0,16	0,80 – 0,20
Resin (non-coated diamond)	D126 – M16	0,32 – 0,05	0,50 – 0,10	0,63 – 0,125
Metal (high productivity)	D213 – D126	1,0 – 0,32	1,25 – 0,63	1,25 – 0,63
	D107 – D91	0,50 – 0,16	1,0 – 0,32	1,25 – 0,40
	D64 – D46	0,32 – 0,16	0,63 – 0,16	0,63 – 0,32

## CONCENTRATION OF DIAMOND GRAIN IN THE DIAMOND LAYER

The concentration of diamond grain is the content by weight of diamond in the diamond layer. The unit of weight for diamond grain is a carat (ct), 1ct=0,2 g. The diamond concentration is one of the most important characteristics of a diamond tool, determining its cutting ability, productivity, length of usage and cost. The choice of concentration depends on the type of tool, the form and size of the working surface, the diamond grit size, the wear-resistance of the bond, and the conditions in which the tool will be used.

The following are guidelines for the choice of diamond concentration in the diamond layer:

- for a small contact surface between the grinding wheel and the workpiece, for example as in circular grinding, a high diamond concentration should be chosen.

This provides higher wear resistance for the wheel, even at high loads:

- a large contact surface necessitates lowering the grinding temperature and the grinding intensity. In this case a lower diamond concentration should be used.

Wheels are produced with diamond concentrations of 25%, 50%, 75%, 100% and 150% (It is possible to produce wheels with other concentrations if needed by the customer).

### Diamond concentration by weight in the diamond layer

Diamond concentration	25%	50%	75%	100%	150%
Diamond weight in carats per 1 cm <sup>3</sup> of the diamond layer, (ct/cm <sup>3</sup> )	1,1	2,2	3,3	4,4	6,6

### Diamond content by volume in the diamond layer (%)

Diamond concentration weight	25%	50%	75%	100%	150%
Diamond volume in the diamond layer (%)	6,25	12,5	18,75	25,0	37,5

Low concentration of diamond grain

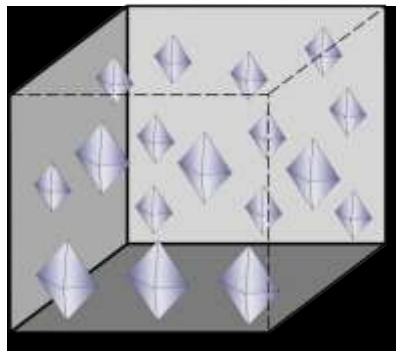

High concentration of diamond grain

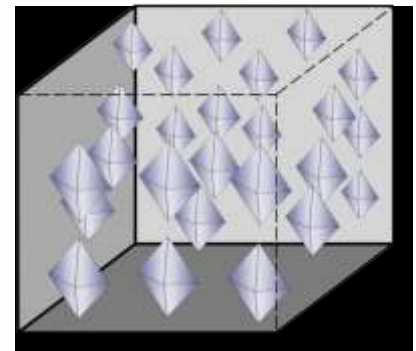

## GRINDING WITH AND WITHOUT COOLANT

Grinding with coolant is to be preferred, since the grinding wheel is subject to less wear and can be used under more demanding conditions, thus increasing grinding productivity. In addition, the probability of thermal damage to the workpiece (the appearance of burn marks) is reduced. Liquid coolants are recommended as coolants for diamond grinding wheels.

## WHEEL PARAMETERS

Parameters used in the catalog are based on the FEPA standard for diamond tools

- D** — top diameter
- H** — hole diameter
- T** — wheel thickness
- U** — insert length
- V** — face angle
- W** — rim width
- X** — depth of diamond layer

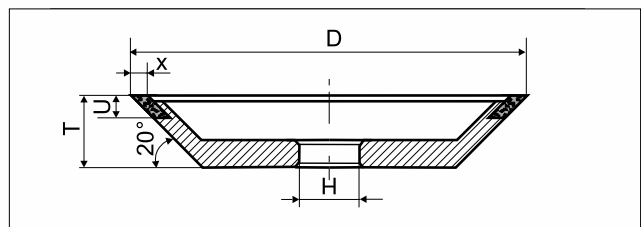
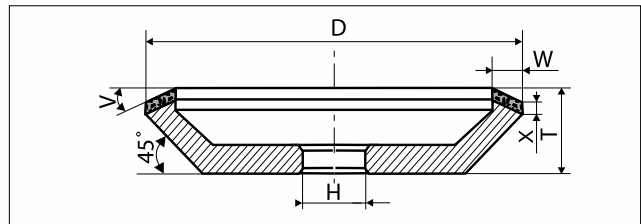
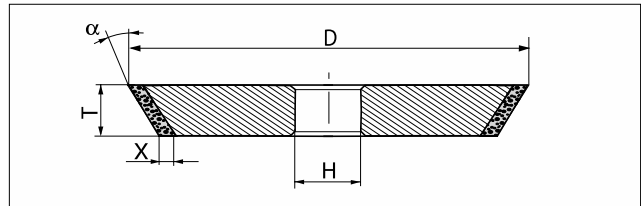

## SHAPES OF DIAMOND GRINDING WHEELS

Diamond grinding wheels described in the catalog are based on the FEPA standard for diamond tools

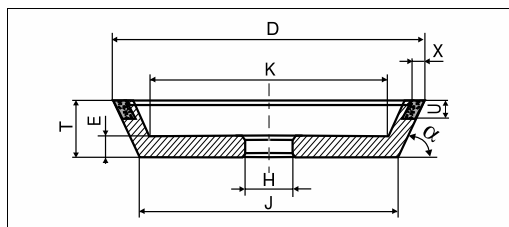

designation of the shape of the wheel core







designation of the shape of the diamond layer

designation of the diamond layer location

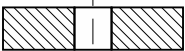
additional information/modification

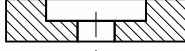
**11 V 9-70**

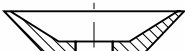
### Identification number for shapes of grinding wheels cores

1		Flat wheel without recesses, $D/H \geq 1,8$
4		Flat wheel with one-sided cone
6		Flat wheel with one-sided recess
11		Cup wheel $45^\circ < \alpha < 90^\circ$
12		Dish wheel $\alpha \leq 45^\circ$
14		Flat wheel with double-sided relief

## OPERATING PROCEDURES FOR GRINDING TUNGSTEN CARBIDE

### 1) Peripheral velocity of the wheel during grinding

Grinding type	Resin bond			
	Diamond		CBN	
	Dry	Wet	Dry	Wet
Face		20 - 30 m/sec		30 - 40 m/sec
Circular internal	8 - 12 m/sec	10 - 20 m/sec	12 - 18 m/sec	15 - 30 m/sec
Circular external		20 - 30 m/sec		30 - 40 m/sec
Sharpening	15 - 22 m/sec	18 - 28 m/sec	20 - 30 m/sec	25 - 35 m/sec

Grinding type	Metal bond	
	Diamond	CBN
	Wet	Wet
Face	20 - 25 m/sec	30 - 37 m/sec
Circular internal	12 - 20 m/sec	18 - 30 m/sec
Circular external	12 - 20 m/sec	18 - 30 m/sec
Sharpening	12 - 20 m/sec	18 - 30 m/sec

### 2) Feed velocity depending on grit size and type of grinding

Grinding type	Diamond grit size	Grinding depth (depending on grit size), mm	Line Feed, m/min	Cross Feed	Peripheral velocity of the workpiece, m/min
Face grinding	D 181-D 251	0,03 - 0,04	10-20	1/5 - 1/3 of the depth of the abrasive layer	-
	D 91 - D 126	0,001 - 0,02	10-20	1/5 - 1/3 of the depth of the abrasive layer	-
	D 54 - D 91	0,005 - 0,01	10-20	1/5 - 1/3 of the depth of the abrasive layer	-
Circular External	D 181 - D 251	0,015-0,03	0,5 - 2,0	-	20 - 40
	D 91 - D 126	0,009 - 0,010	0,5 - 2,0	-	20 - 40
	D 54 - D 91	0,005 - 0,008	0,5 - 2,0	-	20 - 40
Sharpening	D 181 - D 251	0,04 - 0,5	0,5 - 3,0	-	-
	D 91 - D 126	0,04 - 0,1	0,5 - 3,0	-	-
	D 54 - D 91	0,04 - 0,08	0,5 - 3,0	-	-
Flute grinding	D 181 - D 251 *	0,1 - 6,0	0,1 - 3,0	-	-
	D 91 - D 126 *	0,1 - 6,0	0,1 - 3,0	-	-
	D 54 - D 91 *	0,1 - 6,0	0,1 - 3,0	-	-

\* depending on bond

### SUPERABRASIVE TYPE IS ALSO INDICATED BY THE COLOR OF THE WHEEL CORE

**Diamond wheels are of orange color**

**CBN wheels are of wine red color**



## RECOMMENDATIONS FOR THE USE, TRUING AND DRESSING OF DIAMOND WHEELS

When using diamond grinding wheels, the following instructions should be observed:

- grinding wheels are to be mounted on holders or flanges and should not be removed until final usage has occurred;
- the tools are to be mounted securely on the machine spindle in accordance with the technical specifications of the equipment used for diamond tool machining;
- the cleaning of resin bonded diamond wheels is to be performed with a pumice stone, of metal bonded wheels with a green silicon carbide bar made with grit sizes 1 or 2 sizes larger than that of the diamond wheel.

**Dressing (truing)** of the diamond layer is necessary to restore its shape, eliminate defects from its working surface, and to restore the required profile. As a rule this is performed without coolant. The most productive way of dressing a diamond layer is to grind it with abrasive wheels. The dressing is performed by wheels of white alumina and green silicon carbide with vitrified bonds with grit sizes 1 or 2 sizes larger than those of the diamond wheels. Wheels with a hardness of K-H are necessary for dressing resin bond wheels and wheels of a hardness of M-K are necessary for dressing metal bond wheels. The smaller the grit size of the superabrasive material, the softer the dressing tool must be.

### Conditions of diamond layer dressing

Diamond grinding wheel position	Condition of dressing			
	Peripheral speed, m/s		Line feed, m/min	Cross feed, mm/double stroke
	Abrasive wheel	Diamond wheel		
Diamond grinding wheel set on a machine fixture or in the center of circular grinding or sharpening machine	25 – 35	0,5 – 1,0	1,0 – 2,0	0,02 – 0,04
Diamond grinding wheel set on the spindle of a grinding or sharpening machine	30 – 40	25 – 35	0,5 – 1,0	0,02 – 0,04

### Characteristics of vitrified bonded abrasive wheels for dressing diamond layers

Diamond layer characteristics		Characteristics of profiling wheel		
Type of bonds	Diamond grade, FEPA Standard	Abrasive type	Abrasive grades	Hardness
Resin bonds	D181-D126	Aluminum oxide	20; 16; 1	M-L
	D107-D76		12; 10; 8	L-K
	D64-D46		8; 6; 4	K-J
	M40-M16		M40; M28	J



### Packaging of PREMIUM wheels



PREMIUM wheels come in special plastic packaging that prevents damage during transportation and storage.

## Bond types for PREMIUM Grinding Wheels

Item	Recommendations for usage	Recommended grinding parameters
<b>B9-00</b>	Resin bond for grinding, sharpening and finishing of tungsten carbide and high-speed steel workpieces with coolant.	<b>Cutting speed:</b> diamond wheels $V_c=15 - 25$ m/s BN wheels $V_c=\text{up to } 35$ m/s <b>Feed rate</b> $V_f=0,1 - 0,25$ m/min <b>Infeed</b> $a_e=0,1 - 0,2$ mm
<b>B9-01</b>	Resin bond for sharpening and grinding of parts from tungsten carbide and high-speed steel with and without coolant. Softer than B9-00 bond.	<b>Cutting speed:</b> diamond wheels $V_c=15 - 25$ m/s BN wheels $V_c=\text{up to } 35$ m/s <b>Feed rate</b> $V_f=0,1 - 0,25$ m/min <b>Infeed</b> $a_e=0,1 - 0,2$ mm
<b>B7-00</b>	Resin bond for manufacturing and sharpening of tools from tungsten carbide and high-speed steel on CNC machines with coolant. The bond has good cutting properties, wear resistance and high edge resistance.	<b>Cutting speed:</b> diamond wheels $V_c=15 - 25$ m/s BN wheels $V_c=\text{up to } 35$ m/s <b>Feed rate</b> $V_f=0,05 - 0,1$ m/min <b>Infeed</b> $a_e=\text{up to } 2,00$ mm
<b>B6-01</b>	Resin bond for deep infeed grinding (manufacturing and sharpening) of tungsten carbide and high-speed steel tools on CNC machines with coolant. The bond has excellent cutting properties, wear resistance and high edge resistance.	<b>Cutting speed:</b> diamond wheels $V_c=15 - 25$ m/s BN wheels $V_c=\text{up to } 35$ m/s <b>Feed rate</b> $V_f=0,05 - 0,1$ m/min <b>Infeed</b> $a_e=\text{up to } 4,00$ mm
<b>M7-00</b>	Metal bond for deep infeed grinding (manufacturing) of metal cutting tools from tungsten carbide and high-speed steel on CNC machines with coolant. The bond has very high cutting properties, wear resistance and edge resistance.	<b>Cutting speed:</b> diamond wheels $V_c=15 - 25$ m/s BN wheels $V_c=\text{up to } 35$ m/s <b>Feed rate</b> $V_f=0,05$ m/min <b>Infeed</b> $a_e=\text{up to } 6,00$ mm
<b>M7-01</b>	Metal bond for deep infeed grinding (manufacturing) of metal cutting tools from tungsten carbide and high-speed steel on CNC machines with coolant. The bond has very high cutting properties, wear resistance and edge resistance. Works at higher feed rates than M7-00 bond.	<b>Cutting speed:</b> diamond wheels $V_c=15 - 25$ m/s BN wheels $V_c=\text{up to } 35$ m/s <b>Feed rate</b> $V_f=0,05 - 0,08$ m/min <b>Infeed</b> $a_e=\text{up to } 6,00$ mm
<b>RMH01</b>	Hybrid-bond for deep infeed grinding (manufacturing) of metal cutting tools from tungsten carbide and high-speed steel on CNC machines with coolant. The bond has extremely high cutting properties, particular wear resistance and edge resistance. Easy to dress.	<b>Cutting speed:</b> diamond wheels $V_c=15 - 25$ m/s BN wheels $V_c=\text{up to } 35$ m/s <b>Feed rate</b> $V_f=0,05 - 0,1$ m/min <b>Infeed</b> $a_e=\text{up to } 6,00$ mm
<b>B1000</b>	For cutting, sharpening and grinding of tungsten carbide and high-speed steel without coolant.	<b>Cutting speed:</b> diamond wheels $V_c=15 - 25$ m/s BN wheels $V_c=\text{up to } 35$ m/s
<b>B1002</b>	For cylindrical and flat grinding of tungsten carbide and high-speed steel workpieces with coolant.	<b>Cutting speed:</b> diamond wheels $V_c=15 - 25$ m/s BN wheels $V_c=\text{up to } 35$ m/s <b>Feed rate</b> $V_f=5 - 10$ m/min <b>Infeed</b> $a_e=\text{up to } 0,05$ mm

# Grinding machine types and wheels

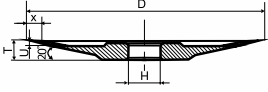
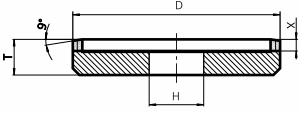
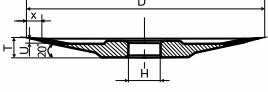
## Sharpening and manufacturing of circular saws

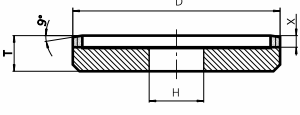
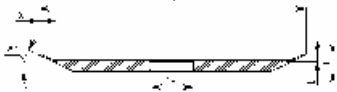
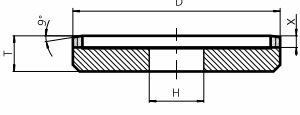
Grinding machine type/ Wheel shape	Grinding wheel					
	Catalog number	Dimensions				
<b>VOLLMER CP 200</b>						
<b>12V9-20</b> 	<b>3-3048</b>	<b>D</b>	<b>T</b>	<b>X</b>	<b>U</b>	<b>H</b>
		125	13	2,5	4	32
<b>12M2-45</b> 	<b>9P3153</b>	<b>D</b>	<b>T</b>	<b>X</b>	<b>W</b>	<b>H</b>
		125	18	6	5	32
					(2,5+2,5)	
<b>VOLLMER CHD 251</b>						
<b>12V9-20</b> 	<b>3-3048</b>	<b>D</b>	<b>T</b>	<b>X</b>	<b>U</b>	<b>H</b>
		125	13	2,5	4	32
	<b>3-3049</b>	<b>D</b>	<b>T</b>	<b>X</b>	<b>U</b>	<b>H</b>
		200	13	2,3	4	32
<b>12V9-25</b> 	<b>3-3068</b>	<b>D</b>	<b>T</b>	<b>X</b>	<b>U</b>	<b>H</b>
		200	13	2,5	5,5	32
<b>12M2-45</b> 	<b>9P3153</b>	<b>D</b>	<b>T</b>	<b>X</b>	<b>W</b>	<b>H</b>
		125	18	6	5	32
					(2,5+2,5)	
<b>VOLLMER CHD 270, CHF 1300</b>						
<b>12V9-25</b> 	<b>3-3068</b>	<b>D</b>	<b>T</b>	<b>X</b>	<b>U</b>	<b>H</b>
		200	13	2,5	5,5	32
<b>VOLLMER CL 200</b>						
<b>12M2-45</b> 	<b>9P3153</b>	<b>D</b>	<b>T</b>	<b>X</b>	<b>U</b>	<b>H</b>
		125	18	6	5	3
					(2,5+2,5)	

## Sharpening and manufacturing of circular saws

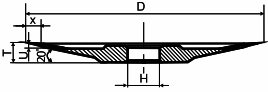
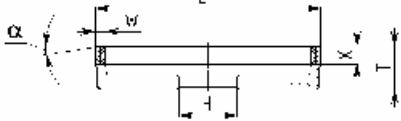
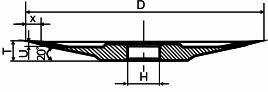
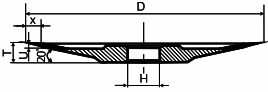
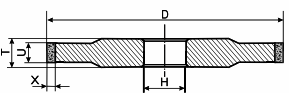
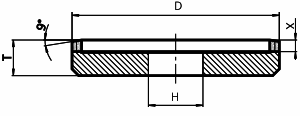
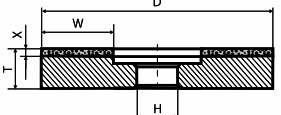
Grinding machine type/ Wheel shape	Grinding wheel						
	Catalog number	Dimensions					
<b>VOLLMER CX 100</b>							
<p style="text-align: center;"><b>12V9-20</b></p> 	<b>3-3048</b>	<b>D</b>	<b>W</b>	<b>X</b>	<b>U</b>	<b>H</b>	
		125	13	2,5	4	32	
<p style="text-align: center;"><b>6A2</b></p> 	<b>3M0008</b>	<b>D</b>	<b>W</b>	<b>X</b>	<b>T</b>	<b>H</b>	$\alpha^\circ$
		125	5	10	24	32	8
		(2,5+2,5)					
<b>WALTER CNC5</b>							
<p style="text-align: center;"><b>12V9-20</b></p> 	<b>3-3049</b>	<b>D</b>	<b>T</b>	<b>X</b>	<b>U</b>	<b>H</b>	
		200	13	2,3	4	32	
<b>AKEMAT U6 R2</b>							
<p style="text-align: center;"><b>12V9-20</b></p> 	<b>3-3049</b>	<b>D</b>	<b>T</b>	<b>X</b>	<b>U</b>	<b>H</b>	
		200	13	2,3	4	32	
<b>WEINIG</b>							
<p style="text-align: center;"><b>14A1</b></p> 	<b>9F3301</b>	<b>D</b>	<b>T</b>	<b>U</b>	<b>X</b>	<b>H</b>	
		200	10	4	5	32	
	<b>0D0324</b>	<b>D</b>	<b>T</b>	<b>U</b>	<b>X</b>	<b>H</b>	
		200	10	5	5	32	
<b>LINSINGER (VOLLMER CHD351)</b>							
<p style="text-align: center;"><b>12M2-45</b></p> 	<b>9M3153</b>	<b>D</b>	<b>T</b>	<b>X</b>	<b>W</b>	<b>H</b>	
		125	24	6	5	32	
		(2,5+2,5)					
<b>GOECKEL</b>							
<p style="text-align: center;"><b>6A2</b></p> 	<b>3M0038</b>	<b>D</b>	<b>W</b>	<b>X</b>	<b>T</b>	<b>H</b>	
		200	10	4	29	32	

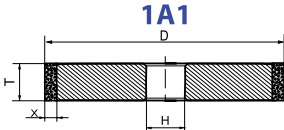
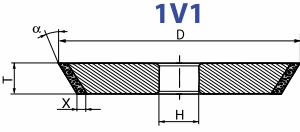
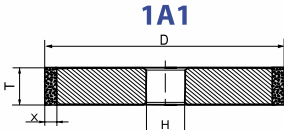
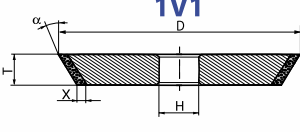
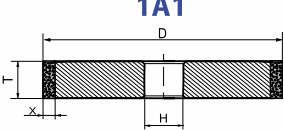
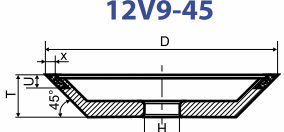
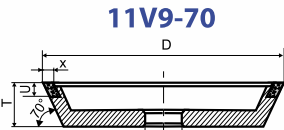
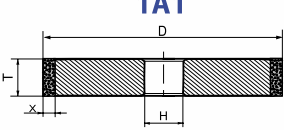
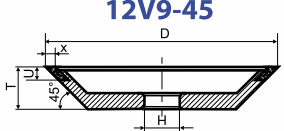
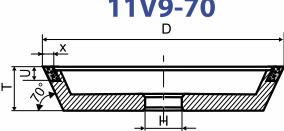
Grinding machine type/ Wheel shape	Grinding wheel					
	Catalog number	Dimensions				
<b>WALTER HMC500</b>						
 <p><b>1A1</b></p>	0-0072	<b>D</b>	<b>T</b>	<b>X</b>	<b>H</b>	
		100	12	5	20	
 <p><b>1V1</b></p>	9B3208	<b>D</b>	<b>T</b>	<b>X</b>	$\alpha^{\circ}$	<b>H</b>
		100	12	6	45	20
<b>WALTER HELITRONIC MINI POWER, POWER 400</b>						
 <p><b>1A1</b></p>	9-8021	<b>D</b>	<b>T</b>	<b>X</b>	<b>H</b>	
		100	10	10	20	
 <p><b>1V1</b></p>	9B3208	<b>D</b>	<b>T</b>	<b>X</b>	$\alpha^{\circ}$	<b>H</b>
		100	12	6	45	20
<b>HAWEMAT 3000 CNC</b>						
 <p><b>1A1</b></p>	9-8021	<b>D</b>	<b>T</b>	<b>X</b>	<b>H</b>	
		100	10	10	20	
 <p><b>12V9-45</b></p>	4-1510	<b>D</b>	<b>U</b>	<b>X</b>	<b>T</b>	<b>H</b>
		100	10	2	20	20
 <p><b>11V9-70</b></p>	4-0110	<b>D</b>	<b>U</b>	<b>X</b>	<b>T</b>	<b>H</b>
		75	10	3	30	20
<b>SAACKE UW I F, UW II F, UW I D, ECLIPSE, EVOLUTION</b>						
 <p><b>1A1</b></p>	1-1071	<b>D</b>	<b>T</b>	<b>X</b>	<b>H</b>	
		100	10	5	20	
 <p><b>12V9-45</b></p>	3-2924	<b>D</b>	<b>U</b>	<b>X</b>	<b>T</b>	<b>H</b>
		125	10	3	25	20
 <p><b>11V9-70</b></p>	3-2924	<b>D</b>	<b>U</b>	<b>X</b>	<b>T</b>	<b>H</b>
		125	10	3	40	20

## Sharpening and manufacturing of metal-cutting tools

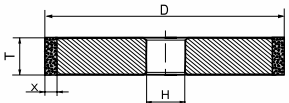
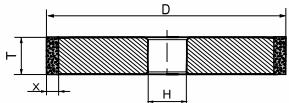
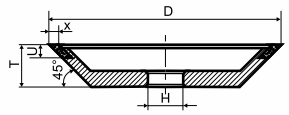
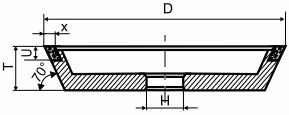
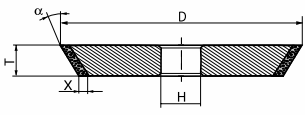
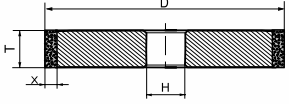
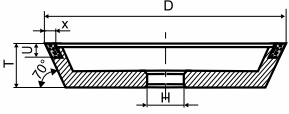
Grinding machine type/ Wheel shape	Grinding wheel					
	Catalog number	Dimensions				
<b>WALTER HELITRONIC POWER 600, VISION 700L</b>						
<b>1A1</b> 	<b>0D0086</b>	<b>D</b>	<b>T</b>	<b>X</b>	<b>H</b>	
		125	12	5	20	
	<b>9-8021</b>	<b>D</b>	<b>T</b>	<b>X</b>	<b>H</b>	
		100	10	10	20	
<b>MICHAEL DECKEL S20E TURBO</b>						
<b>1A1</b> 	<b>0-0071</b>	<b>D</b>	<b>T</b>	<b>X</b>	<b>H</b>	
		100	10	5	20	
<b>12V9-45</b> 	<b>3-2841</b>	<b>D</b>	<b>U</b>	<b>X</b>	<b>T</b>	<b>H</b>
		100	10	3	20	20
<b>11V9-70</b> 	<b>4-0103</b>	<b>D</b>	<b>U</b>	<b>X</b>	<b>T</b>	<b>H</b>
		100	6	2	40	31,75
<b>ANCA RX7, MX5 Linear, MX7 Linear, FX3 Linear, FX5 Linear, FX7 Linear, GCX Linear</b>						
<b>1V1</b> 	<b>9-3249</b>	<b>D</b>	<b>T</b>	<b>X</b>	<b><math>\alpha^{\circ}</math></b>	<b>H</b>
		100	6	5	45	31,75
	<b>9-3241</b>	<b>D</b>	<b>T</b>	<b>X</b>	<b><math>\alpha^{\circ}</math></b>	<b>H</b>
		125	10	6	45	31,75
<b>1A1</b> 	<b>0-0174</b>	<b>D</b>	<b>T</b>	<b>X</b>	<b>H</b>	
		125	10	10	31,75	
<b>11V9-70</b> 	<b>4M0104</b>	<b>D</b>	<b>U</b>	<b>X</b>	<b>T</b>	<b>H</b>
		100	10	2	35	31,75

# 1A1 STRAIGHT GRINDING WHEELS

### Application:

- Used for machining of conical, cylindrical and flat surfaces, cylindrical and conical apertures;
- Machining of cylindrical surface parts and surface ends at one set-up;
- Sharpening and finishing of carbide tools;
- Flute grinding, rotary tools production.

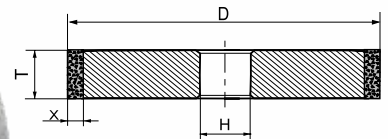

1A1 D\*T\*X\*H

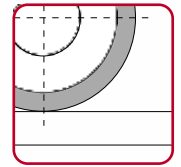

Flat surface grinding

Catalog number D	D, mm T	T, mm	X, mm H	H, mm
0-0048	80	6	3	20
0-0054	80	6	5	20
0-0050	80	10	3	20
0-0056	80	10	5	20
0-0053	80	20	3	20
0-0059	80	20	5	20
0-0063	100	6	3	20
0-0065	100	10	3	20
0-0071	100	10	5	20
0-0068	100	20	3	20
0-0079	125	6	3	32
0-0080	125	10	3	32
0-0085	125	10	5	32
0-0174	125	10	10	31,75
0-0083	125	20	3	32
0-0088	125	20	5	32
0-0089	125	32	5	32
0-0094	150	6	3	32
0-0100	150	6	5	32
0-0096	150	10	3	32
0-0102	150	10	5	32
0-0099	150	20	3	32
0-0105	150	20	5	32
0-0109	200	6	3	76
0-0116	200	10	5	76
0-0119	200	20	5	76
0-0120	200	40	5	76
0-0126	250	10	5	76
0-0129	250	20	5	76
0-0131	250	50	5	76
0-0145	300	15	5	127
0-0146	300	20	5	127
0-0139	300	40	5	76
0-0149	350	20	5	127
0-0150	400	10	4	127
9-7004	400	20	5	127
0-0154	400	25	6	127
0-0155	400	40	6	127
0-0162	500	20	6	203
0-0167	500	32	20	203
0-0169	500	50	6	305
600-25	600	25	6	127
600-40	600	40	6	305

Example of an order for a straight grinding wheel 1A1 (catalog number 0-0065), parameters 100-10-3-20 with diamond grit size D76, with resin bond: **0-0065 1A1 100-10-3-20 D76 B6-00 PREMIUM**

**The plant produces the above-mentioned shapes and dimensions with Cubic Boron Nitride (CBN).**

Example of an order for a straight CBN wheel 1A1 (catalog number 0-0065), parameters 100-10-3-20 with CBN grit size B76, with resin bond: **0-0065 1A1 100-10-3-20 B76 B6-00 PREMIUM**

**Other specifications and sizes are available on request.**

# 14A1 STRAIGHT FLAT GRINDING WHEELS

## Application:

- Used for machining of conical, cylindrical and flat surfaces, cylindrical and conical apertures;
- Machining of cylindrical surface parts and surface ends at one set-up;
- Sharpening and finishing of carbide tools;
- Flute grinding.

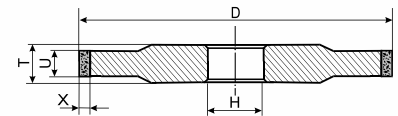

14A1 D\*T\*U\*X\*H

Cylindrical surface grinding

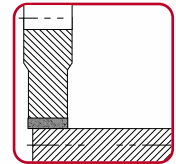

Catalog number	D, mm	T, mm	U, mm	X, mm	H, mm
0-0301	100	6	3	3	20
0-0304	100	6	5	5	20
0-0305	125	6	3	3	32
0-0306	125	6	5	3	32
0-0309	150	8	3	3	32
0-0312	150	8	5	5	32
0-0316	150	10	9	7	32
0-0319	175	8	3	5	51
0-0320	175	8	5	5	51
0-0322	200	10	5	3	51
0-0327	200	10	7	7	51
0-0329	200	10	3	5	51
0-0333	250	10	7	7	51
0-0335	250	10	5	5	76

Example of an order for a straight grinding wheel 14A1 (catalog number 0-0309), parameters 150-8-3-3-32 with diamond grit size D76, with resin bond: **0-0309 14A1 150-8-3-3-32 D76 B6-00 PREMIUM**

The plant produces the above-mentioned shapes and dimensions with Cubic Boron Nitride (CBN).

Example of an order for a straight CBN wheel 14A1 (catalog number 0-0309), parameters 150-8-3-3-32, with CBN grit size B76, with resin bond: **0-0309 14A1 150-8-3-3-32 B76 B6-00 PREMIUM**

Other specifications and sizes are available on request.

# 1A1R CUT-OFF WHEELS

## Application:

- Used for cutting of carbide and high-speed steels.

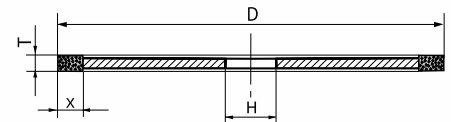

1A1R D\*T\*X\*H

Material cutting

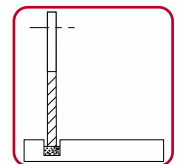

Catalog number	D, mm	T, mm	X, mm	H, mm
9-1003	75	1.0	5	10
6-0167	100	1.0	5	20
6-0206	150	1.2	5	32
6-4002	200	1.0	10	32
6D0234	200	1.5	5	30
6Q0234	200	1.2	5	30
6M0701	300	1.2	10	35

Example of an order for cut off wheels 1A1R (catalog number 6-0206), parameters 150-1.2-5-32 with diamond grit size D251, with resin bond: **6-0206 1A1R 150-1.2-5-32 D251 B1000 PREMIUM**

The plant produces the above-mentioned shapes and dimensions with Cubic Boron Nitride (CBN).

Example of an order for cut off wheels 1A1R (catalog number 6-0206), parameters 150-1.2-5-32 with CBN grit size B213, with resin bond: **6-0206 1A1R 150-1.2-5-32 B213 B1000 PREMIUM**

Other specifications and sizes are available on request.

# 1V1 GRINDING WHEELS

### Application:

- Used for grinding of cylindrical and tapered surfaces;
- Grinding of chip grooves and flute grinding.

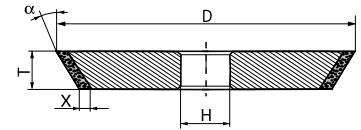

1V1 D\*T\*X\* $\alpha$ \*H

Machining of teeth

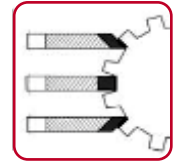

Catalog number	D, mm	T, mm	X, mm	$\alpha$ , °	H, mm
9-3248	100	6	5	30	31,75
9-3249	100	6	5	45	31,75
9-3222	100	10	3	20	20,00
9B9999	100	10	6	30	20,00
9-3206	100	12	6	15	31,75
9-3207	100	12	6	30	31,75
9-3208	100	12	6	45	31,75
9-3220	125	6	6	30	50,80
9-3241	125	10	6	45	31,75
9-3262	125	10	6	45	20,00
9-3209	125	12	6	15	31,75
9-3214	125	12	3	10	31,75
9-3215	125	12	3	15	31,75
9-3216	125	12	3	20	31,75
9-3217	125	12	3	25	31,75
9-3218	125	12	3	30	31,75
9-3219	125	12	3	45	31,75

Example of an order for a wheel 1V1 (catalog number 9-3248), parameters 100-6-5-30-31,75 with diamond grit size D64, with resin bond: **9-3248 1V1 100-6-5-30-31,75 D64 B7-00 PREMIUM**

The plant produces the above-mentioned shapes and dimensions with Cubic Boron Nitride (CBN).

Example of an order for a CBN wheel 1V1 (catalog number 9-3248), parameters 100-6-5-30-31,75, with CBN grit size B64, with resin bond: **9-3248 1V1 100-6-5-30-31,75 B64 B7-00 PREMIUM**

Other specifications and sizes are available on request.

# 14EE1 FLAT GRINDING WHEELS WITH DOUBLE-SIDED CONICAL PROFILE

### Application:

- Grinding of profiled workpieces made of carbide and other hard-to-process materials.

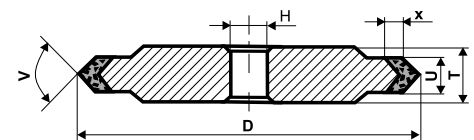

14EE1 D\*T\*U\*X\*V\*H

Profile grinding

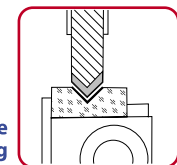

Catalog number	D, mm	T, mm	U, mm	X, mm	V, °	H, mm
7-0162	80	10	7	5	40	22
9-3229	125	6	3	3	90	32
9-3133	125	6	3	4	60	32
9-3203	125	6	3	6	35	32
9-3251	150	6	3	4	60	32
9-3201	150	6	3	4	50	32
3-2840	200	12	5	4	30	32

Example of an order for a grinding wheel 14EE1 (catalog number 9-3133), parameters 125-6-3-4-60-32 with diamond grit size D64, with resin bond: **9-3133 14EE1 125 6-3-4-60-32 D64 B7-00 PREMIUM**

The plant produces the above-mentioned shapes and dimensions with Cubic Boron Nitride (CBN).

Example of an order for a CBN wheel 14EE1 (catalog number 9-3133), parameters 125-6-3-4-60-32 with CBN grit size B64, with resin bond: **9-3133 14EE1 125 6-3-4-60-32 B64 B7-00 PREMIUM**

# 1FF1

## FLAT GRINDING WHEELS WITH SEMICIRCULAR-CONVEX PROFILE

### Application:

- Used for machining chip-breaking flutes in tools;
- Profile grinding.

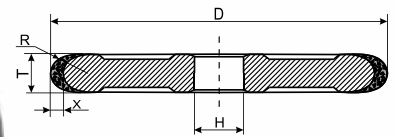

1FF1 D\*T\*X\*R\*H

Profile grinding

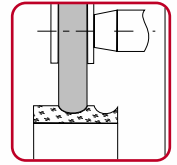

Catalog number	D, mm	T, mm	X, mm	R, mm	H, mm
9-0001	50	2	2	1	16
9-0003	50	4	4	2	16
9-0004	75	4	4	2	20
9-0008	75	10	4	5	20
5-9156	80	40	5	26	32
9-0009	100	4	4	2	20
9-0016	100	20	6	10	20
9-0017	125	4	4	2	32
9-0019	125	6	4	3	32
9-0021	125	10	4	5	32
9-0025	150	10	4	5	32
9-0028	150	20	6	10	32
9-0029	200	20	6	10	51
9-0030	200	30	6	15	51
9-0031	250	20	6	10	51
9-2802	300	30	5	15	42

Example of an order for a wheel 1FF1 (catalog number 9-0017), parameters 125-4-4-2-32 with diamond grit size D76, with resin bond: **9-0017 1FF1 125-4-4-2-32 D76 B7-00 PREMIUM**

The plant produces the above-mentioned shapes and dimensions with Cubic Boron Nitride (CBN).

Example of an order for a CBN wheel 1FF1 (catalog number 9-0017), parameters 125-4-4-2-32, with CBN grit size B76, with resin bond: **9-0017 1FF1 125-4-4-2-32 B76 B7-00 PREMIUM**

Other specifications and sizes are available on request.

# 14FF1

## FLAT GRINDING WHEELS WITH SEMICIRCULAR-CONVEX PROFILE

### Application:

- Used for machining chip-breaking flutes in tools;
- Profile grinding.

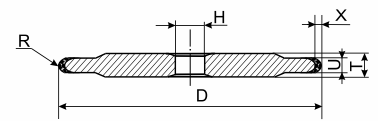

14FF1 D\*T\*U\*X\*R\*H

Profile grinding



Catalog number	D, mm	T, mm	U, mm	X, mm	R, mm	H, mm
9-2515	150	8,5	4	4	2	32
9-2653	200	10	3	4	1,5	60
9-2640	200	10	4	4	2	60
9-2655	200	10	6	4	3	60
9-0304	200	12	10	5	5	127

Example of an order for a wheel 14FF1 (catalog number 9-2515), parameters 150-8,5-4-4-2-32 with diamond grit size D76, with resin bond: **9-2515 14FF1 150-8,5-4-4-2-32 D76 B7-00 PREMIUM**

The plant produces the above-mentioned shapes and dimensions with Cubic Boron Nitride (CBN).

Example of an order for a CBN wheel 14FF1 (catalog number 9-2515), parameters 150-8,5-4-4-2-32, with CBN grit size B76, with resin bond: **9-2515 14FF1 150-8,5-4-4-2-32 B76 B7-00 PREMIUM**

Other specifications and sizes are available on request.

# 12A2-45 CUP GRINDING WHEELS

### Application:

- Used for sharpening and finishing of front and back surfaces of multiple-blade carbide tools (with straight and spiral teeth), cutters, drills and other tools.

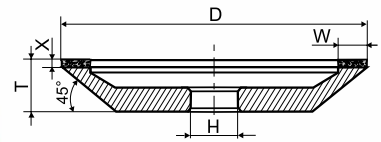

12A2-45° D\*W\*X\*T\*H

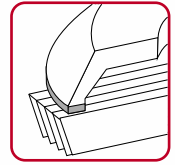

Face grinding

Catalog number	D, mm	W, mm	X, mm	T, mm	H, mm
4-0015	100	3	3	32	20
4-0016	100	5	3	32	20
4-0017	100	10	3	32	20
4-0027	125	3	3	40	32
4-0028	125	5	3	40	32
4-0029	125	10	3	40	32
4-0031	125	5	5	42	32
4-0040	150	10	3	40	32
4-0043	150	10	5	42	32
4-0041	150	20	3	40	32
9-0044	150	20	5	42	32

Other specifications and sizes are available on request.

# 11V9-70 TAPERED CUP GRINDING WHEELS

### Application:

- Used for sharpening and finishing of back and side surfaces of carbide tools.

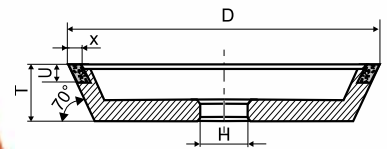

11V9-70° D\*U\*X\*T\*H

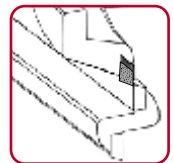

Sharpening of back and side surfaces



Type 1

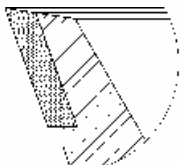

Type 2

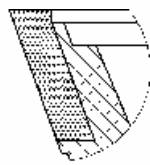

Type 3

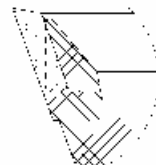

Type 4

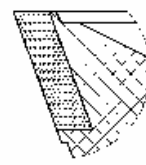

Type 5

Catalog number	D, mm	U, mm	X, mm	T, mm	H, mm	Wheel type
4-0110	75	10	3	30	20	5
4-0111	95,2	11	3,2	38,1	31,75	3
4-0101	50	3	1,5	20	16	2
4-0102	75	6	2	32	20	2; 4
4-0103	100	6	2	40	20	2; 4
4-0104	100	10	2	40	20	2; 4
4M0104	100	10	2	35	31.75	2
9M5002	100	10	3	35	20	1
4-0106	125	8	3	40	32	2; 4
4-0107	125	10	3	40	32	2
4-0108	150	6	3	40	32	2; 4
4-0109	150	10	3	40	51	2; 4

Example of an order for a cup wheel 11V9-70 (catalog number 4-0109), parameters 150-10-3-40-51 with diamond grit size D126, with resin bond: **4-0109 11V9-70 150-10-3-40-51 D126 B9-00 PREMIUM**

The plant produces the above-mentioned shapes and dimensions with Cubic Boron Nitride (CBN).

Example of an order for a CBN wheel 11V9-70 (catalog number 4-0109), parameters 150-10-3-40-51, with CBN grit size B54, with resin bond: **4-0109 11V9-70 150-10-3-40-51 B54 B9-00 PREMIUM**

Other specifications and sizes are available on request.

# 12V5-45 CUP GRINDING WHEELS

### Application:

- Used for sharpening and finishing (top grinding) of multiple-blade carbide tools (with straight and spiral teeth), cutters, drills and other tools.

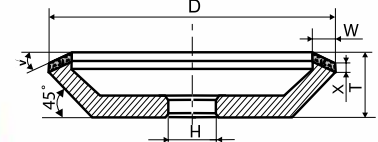
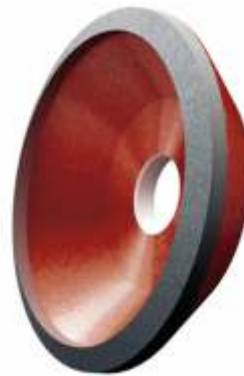

12V5-45° D\*T\*W\*X\*V\*H

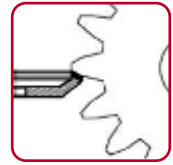

Ram sharpening

Catalog number	D, mm	T, mm	W, mm	X, mm	V, °	H, mm
4-0127	100	32	3	4	15	20
4-0128	100	32	3	4	25	20
4-0129	100	32	6	4	15	20
4-0130	100	32	6	4	25	20
4-0131	125	40	3	4	15	32
4-0132	125	40	3	4	25	32
4-0133	125	40	6	4	15	32
4-0134	125	40	6	4	25	32
4-0135	150	40	6	5	15	32
9-0136	150	40	6	5	25	32
9-0137	150	40	6	5	15	51
9-0138	150	40	6	5	25	51

Example of an order for a cup wheel 12V5-45 (catalog number 4-0129), parameters 100-32-6-4-15-20 with diamond grit size D126, with resin bond: **4-0129 12V5-45 100-32-6-4-15-20 D126 B9-00 PREMIUM**

The plant produces the above-mentioned shapes and dimensions with Cubic Boron Nitride (CBN).

Example of an order for a CBN wheel 12V2-45 (catalog number 4-0129), parameters 100-32-6-4-15-20, with CBN grit size B107, with resin bond: **4-0129 12V5-45 100-32-6-4-15-20 B107 B9-00 PREMIUM**

Other specifications and sizes are available on request.

# 12V9-45 CUP GRINDING WHEELS

### Application:

- Used for sharpening and finishing (top grinding) of cutting tools.

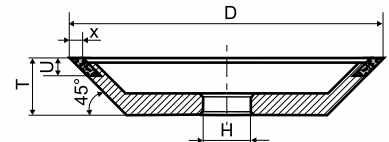

12V9-45° D\*U\*X\*T\*H

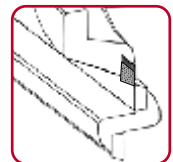

Top grinding

Catalog number	D, mm	U, mm	X, mm	T, mm	H, mm
4-2513	75	10	4	12	31,75
4-2503	75	6	1,5	18	31,75
4-1503	75	6	2	20	20
9-3154	75	6	3,5	20	10
9-3107	75	10	6	20	20
4-2510	100	6	1,5	18	31,75
9-3109	100	6	3	20	20
4-1510	100	10	2	20	20
4-2512	100	10	3	20	31,75
9-3108	125	10	3	25	20

Example of an order for a cup wheel 12V9-45 (catalog number 4-1503), parameters 75-6-2-20-20 with diamond grit size D76, with resin bond: **4-1503 12V9-45 75-6-2-20-20 D76 B9-00 PREMIUM**

The plant produces the above-mentioned shapes and dimensions with Cubic Boron Nitride (CBN).

Example of an order for a CBN wheel 12V9-45 (catalog number 4-1503), parameters 75-6-2-20-20, with CBN grit size B76, with resin bond: **4-1503 12V9-45 75-6-2-20-20 B76 B9-00 PREMIUM**

Other specifications and sizes are available on request.

# 12V9-20 DISH GRINDING WHEELS

**Application:**

- Used for sharpening and finishing (face grinding) of circular saw teeth and other tungsten carbide and HSS tools.

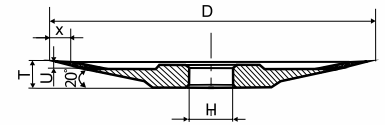

12V9-20° D\*T\*X\*U\*H

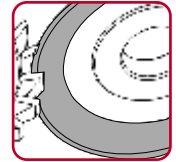

Face grinding

Catalog number	D, mm	T, mm	X, mm	U, mm	H, mm
3-3048	125	13	2,5	4	32
3D3048	125	13	2,5	4	20
3-3045	150	13	2,3	4	32
3-3043	175	13	2,5	4	32
3-3049	200	13	2,3	4	32

Example of an order for a dish wheel 12V9-20 (catalog number 3-3048), parameters 125-13-2,5-4-32 with diamond grit size D64, with resin bond: **3-3048 12V9-20 125-13-2,5-4-32 D64 B9-00 PREMIUM**

**The plant produces the above-mentioned shapes and dimensions with Cubic Boron Nitride (CBN).**

Example of an order for a CBN wheel 12V9-20 (catalog number 3-3048), parameters 125-13-2,5-4-32 with CBN grit size B64, with resin bond: **3-3048 12V9-20 125-13-2,5-4-32 B64 B9-00 PREMIUM**

**Other specifications and sizes are available on request.**

# 12V9-25 DISH GRINDING WHEELS

**Application:**

- Used for sharpening and finishing (face grinding) of circular saw teeth and other tungsten carbide and HSS tools.

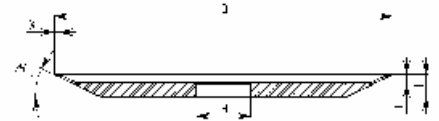

12V9-25° D\*T\*X\*U\*H

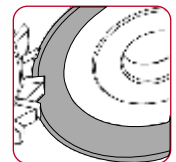

Face grinding

Catalog number	D, mm	T, mm	X, mm	U, mm	H, mm
3-3069	75	10	2,3	4	20
3-3068	200	13	2,5	5,5	32

Example of an order for a dish wheel 12V9-25 (catalog number 3-3068), parameters 200-13-2,5-5,5-32 with diamond grit size D64, with resin bond: **3-3068 12V9-25 200-13-2,5-5,5-32 D64 B9-00 PREMIUM**

**The plant produces the above-mentioned shapes and dimensions with Cubic Boron Nitride (CBN).**

Example of an order for a CBN wheel 12V9-25 (catalog number 3-3068), parameters 200-13-2,5-5,5-32 with CBN grit size B64, with resin bond: **3-3068 12V9-25 200-13-2,5-5,5-32 B64 B9-00 PREMIUM**

**Other specifications and sizes are available on request.**

# 4V2 DISH GRINDING WHEELS

### Application:

- Used for sharpening and finishing (face grinding) of circular saw teeth and other tungsten carbide and HSS tools.

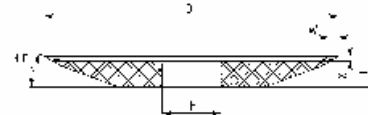

4V2 D\*W\*X\*T\*H

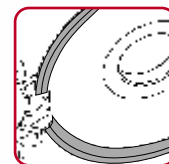

Face grinding

Catalog number	D, mm	W, mm	X, mm	T, mm	H, mm
0-3001	100	4	2	13	25
0Q3002	125	4	2	13	32

Example of an order for a dish wheel 4V2 (catalog number 0-3001), parameters 100-4-2-13-25 with diamond grit size D46, with resin bond: **0-3001 4V2 100-4-2-13-25 D46 B9-00 PREMIUM**

**The plant produces the above-mentioned shapes and dimensions with Cubic Boron Nitride (CBN).**

Example of an order for a CBN wheel 4V2 (catalog number 0-3001), parameters 100-4-2-13-25 with CBN grit size B46, with resin bond: **0-3001 4V2 100-4-2-13-25 B46 B9-00 PREMIUM**

**Other specifications and sizes are available on request.**

# 4BT9 DISH GRINDING WHEELS

### Application:

- Used for sharpening and finishing (face grinding) of circular saw teeth and other tungsten carbide and HSS tools.

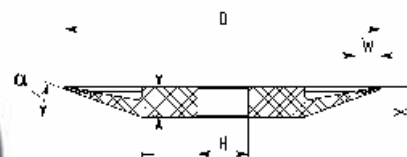

4BT9 D\*T\*X\*W\*H

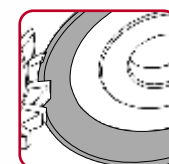

Face grinding

Catalog number	D, mm	T, mm	X, mm	W, mm	H, mm
5-0400	75	8	1	10	20
3-3035	125	12	1	10	20

Example of an order for a dish grinding wheels 4BT9 (catalog number 3-3035), parameters 125-12-1-10-20 with diamond grit size D64, with resin bond: **3-3035 4BT9 125-12-1-10-20 D64 B9-00 PREMIUM**

**The plant produces the above- mentioned shapes and dimensions with Cubic Boron Nitride (CBN).**

Example of an order for a dish grinding wheels 4BT9 (catalog number 3-3035), parameters 125-12-1-10-20 with CBN grit size B64, with resin bond: **3-3035 4BT9 125-12-1-10-20 B64 B9-00 PREMIUM**

**Other specifications and sizes are available on request.**

# 12R4 DISH GRINDING WHEELS

**Application:**

- Used for sharpening and finishing of front surfaces of reamer teeth, cutters, circular saws, drawing dies and tools made of tungsten carbide and HSS.

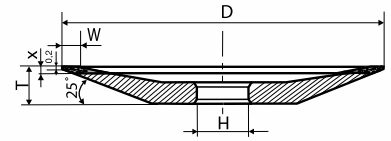

12R4 D\*W\*X\*T\*H

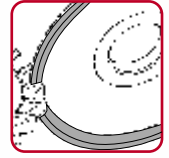

Face grinding

Catalog number	D, mm	W, mm	X, mm	T, mm	H, mm
5-0041	50	2	1,5	6	16
5-0042	75	3	2	10	20
5-1031	100	3	2	10	32
5-1041	125	3	2	13	32
5-1051	150	5	3	16	32
5-1052	150	5	3	16	51

Example of an order for a dish wheel 12R4 (catalog number 5-1041), parameters 125-3-2-13-32 with diamond grit size D64, with resin bond: **5-1041 12R4 125-3-2-13-32 D64 B9-00 PREMIUM**

The plant produces the above-mentioned shapes and dimensions with Cubic Boron Nitride (CBN).

Example of an order for a CBN wheel 12R4 (catalog number 5-1041), parameters 125-3-2-13-32, with CBN grit size B64, with resin bond: **5-1041 12R4 125-3-2-13-32 B64 B9-00 PREMIUM**

Other specifications and sizes are available on request.

# 4B2 DISH GRINDING WHEELS

**Application:**

- Used for sharpening and finishing (face grinding) of circular saw teeth and other tungsten carbide and HSS tools.

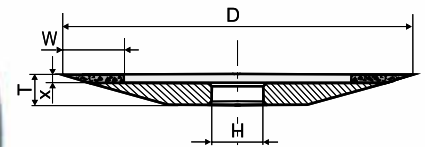

4B2 D\*T\*X\*W\*H

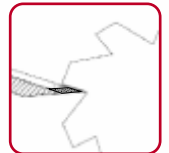

Face grinding

Catalog number	D, mm	T, mm	X, mm	W, mm	H, mm
8-7002	100	10	1,5	6	31,75
8-7010	100	10	1,5	6	32
8-7008	125	10	2	6	32
8-7004	150	12	1,5	6	31,75
8-7009	150	12	1,5	6	32

Example of an order for a dish wheel 4B2 (catalog number 8-7008), parameters 125-10-2-6-32 with diamond grit size D64, with resin bond: **8-7008 4B2 125-10-2-6-32 D64 B9-00 PREMIUM**

The plant produces the above-mentioned shapes and dimensions with Cubic Boron Nitride (CBN).

Example of an order for a CBN wheel 4B2 (catalog number 8-7008), parameters 125-10-2-6-32, with CBN grit size B64, with resin bond: **8-7008 4B2 125-10-2-6-32 B64 B9-00 PREMIUM**

Other specifications and sizes are available on request.

# 6A2 FLAT RECESSED GRINDING WHEELS

### Application

- Used for sharpening and finishing (top grinding) of circular saw teeth and other tungsten carbide and HSS tools.

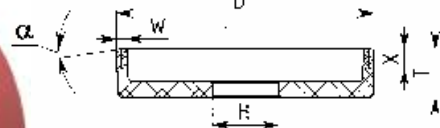

6A2 D\*W\*X\*T\*H\*α°

Sharpening of circular saw

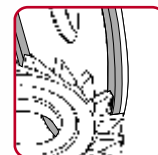

Catalog number	D, mm	W, mm	X, mm	T, mm	H, mm	α°
3K2671	100	5(2,5+2,5)	10	24	25	4
3-0088	125	5(2,5+2,5)	10	24	32	—
3M0088	125	5(2,5+2,5)	10	24	32	8
3J0088	125	5(2,5+2,5)	10	24	32	4

Example of an order for a grinding wheels 6A2 (catalog number 3-0088), parameters 125-5(2,5+2,5)-10-24-32 with diamond grit size D46/D126, with resin bond: **3-0088 6A2 125-5(2,5+2,5)-10-24-32 D46/D126 B9-00 PREMIUM**

The plant produces the above- mentioned shapes and dimensions with Cubic Boron Nitride (CBN).

Example of an order for a grinding wheels 6A2 (catalog number 3-0088), parameters 125-5(2,5+2,5)-10-24-32 with CBN grit size B46/B126, with resin bond: **3-0088 6A2 125-5(2,5+2,5)-10-24-32 B46/B126 B9-00 PREMIUM**

Other specifications and sizes are available on request.

# 12M2-45 GRINDING WHEELS

### Application

- Used for sharpening and finishing (top grinding) of circular saw teeth and other tungsten carbide and HSS tools.

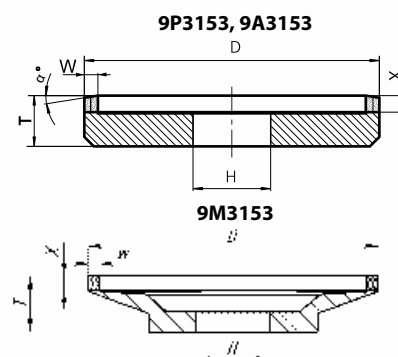

12M2-45 D\*T\*X\*W\*H\*α°

Sharpening of circular saw

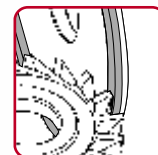

Catalog number	D, mm	T, mm	X, mm	W, mm	H, mm	α°
9P3153	125	18	6	5(2,5+2,5)	32	9
9Q3153	125	18	6	5(2,5+2,5)	32	4
9M3153	125	24	6	5(2,5+2,5)	32	—

Example of an order for a grinding wheels 12M2-45 (catalog number 9P3153), parameters 125-18-6-5(2,5+2,5)-32 with diamond grit size D46/D126, with resin bond: **9P3153 12M2-45 125-18-6-5(2,5+2,5)-32 D46/D126 B9-00 PREMIUM**

The plant produces the above- mentioned shapes and dimensions with Cubic Boron Nitride (CBN).

Example of an order for a grinding wheels 12M2-45 (catalog number 9P3153), parameters 125-18-6-5(2,5+2,5)-32 with CBN grit size B46/B126, with resin bond: **9P3153 12M2-45 125-18-6-5(2,5+2,5)-32 B46/B126 B9-00 PREMIUM**

Other specifications and sizes are available on request.

# 4A2 DISH GRINDING WHEELS

**Application:**

- Used for sharpening and finishing (face grinding) of multiple-blade tools.

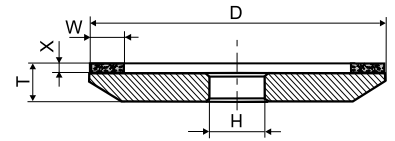

4A2 D\*T\*X\*W\*H



Milling cutter face grinding

Catalog number	D, mm	T, mm	X, mm	W, mm	H, mm
9-8151	100	10	2	3	20
4-1140	100	10	1	6	22,20
4-1116	100	10	1,5	6	31,75
9-9161	125	10	3	6	31,75
9-9166	125	10	3	6	32
9-9165	125	10	2	8	20
9-8158	150	12	3	5	20
9-9162	150	12	3	6	31,75
9-9167	150	12	3	6	32

Example of an order for a dish wheel 4A2 (catalog number 9-8151), parameters 100-10-2-3-20 with diamond grit size M63, with resin bond: **9-8151 4A2 100-10-2-3-20 M63 B9-00 PREMIUM**

The plant produces the above-mentioned shapes and dimensions with Cubic Boron Nitride (CBN).

Example of an order for a CBN wheel 4A2 (catalog number 9-8151), parameters 100-10-2-3-20, with CBN grit size B126, with resin bond: **9-8151 4A2 100-10-2-3-20 B126 B9-00 PREMIUM**

Other specifications and sizes are available on request.

# 12A2-20 DISH GRINDING WHEELS

**Application:**

- Used for sharpening and finishing of front surfaces of reamer teeth, cutters, circular saws, drawing dies and tools made of tungsten carbide and HSS.

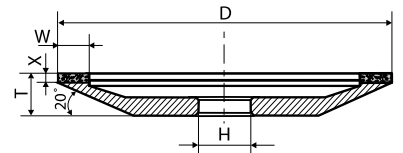

12A2-20° D\*T\*X\*W\*H



Tool face sharpening

Catalog number	D, mm	T, mm	X, mm	W, mm	H, mm
5-0005	75	10	2	3	16
5-0006	75	10	2	6	16
5-0007	100	12	2	3	20
5-0008	100	12	2	6	20
5-0009	125	16	2	3	32
5-0010	125	16	2	6	32
5-0011	125	16	2	10	32
5-0012	150	18	2	3	51
5-0013	150	18	2	6	51
5-0014	150	18	2	10	51

Example of an order for a dish wheel 12A2-20 (catalog number 5-0014), parameters 150-18-2-10-51 with diamond grit size D64, with resin bond: **5-0014 12A2-20 150-18-2-10-51 D64 B9-00 PREMIUM**

The plant produces the above-mentioned shapes and dimensions with Cubic Boron Nitride (CBN).

Example of an order for a CBN wheel 12A2-20 (catalog number 5-0014), parameters 150-18-2-10-51, with CBN grit size B64, with resin bond: **5-0014 12A2-20 150-18-2-10-51 B64 B9-00 PREMIUM**

Other specifications and sizes are available on request.

# 6A9 RECESSED FLAT GRINDING WHEELS

### Application:

- Used for sharpening and finishing of special tools.

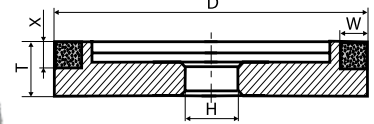

6A9 D\*W\*X\*T\*H



Saw end surface sharpening

Catalog number	D, mm	W, mm	X, mm	T, mm	H, mm
9-8150	100	3	6	30	20
9-3421	125	3	6,5	18	32
3-2843	125	5(2,5+2,5)	6	20	32

Example of an order for a wheel 6A9 (catalog number 9-8150), parameters 100-3-6-30-20 with diamond grit size M63, with resin bond: **9-8150 6A9 100-3-6-30-20 M63 B9-00 PREMIUM**

**The plant produces the above-mentioned shapes and dimensions with Cubic Boron Nitride (CBN).**

Example of an order for a CBN wheel 6A9 (catalog number 9-8150), parameters 100-3-6-30-20, with CBN grit size B54, with resin bond: **9-8150 6A9 100-3-6-30-20 B54 B9-00 PREMIUM**

Other specifications and sizes are available on request.

# 12V5-20 DISH GRINDING WHEELS

### Application:

- Used for sharpening and finishing of multiple-blade tools cutter back surfaces (with straight and spiral teeth), drills and other tools made of tungsten carbide and HSS.

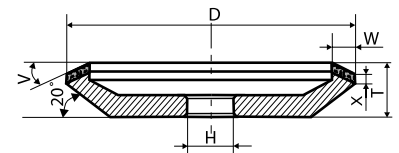

12V5-20 D\*T\*W\*X\*V\*H

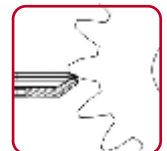

Ram sharpening

Catalog number	D, mm	T, mm	W, mm	X, mm	V, °	H, mm
5-0078	75	10	5	2	25	20
5-0080	100	10	3	2	25	20
5-0086	125	13	5	2	25	32
5-0090	150	16	10	3	25	32











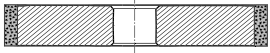
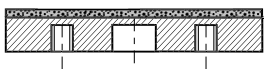
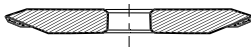
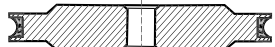

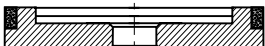

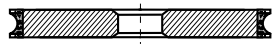

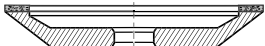
Example of an order for a dish wheel 12V5-20 (catalog number 5-0086), parameters 125-13-5-2-25-32 with diamond grit size D126, with resin bond: **5-0086 12V5-20 125-13-5-2-25-32 D126 B9-00 PREMIUM**

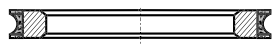
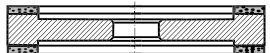
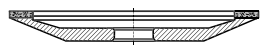
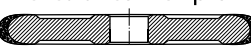
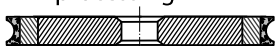
**The plant produces the above-mentioned shapes and dimensions with Cubic Boron Nitride (CBN).**

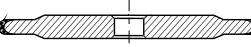
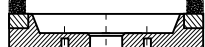
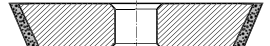
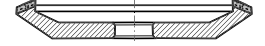
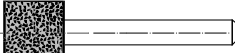
Example of an order for a CBN wheel 12V5-20 (catalog number 5-0086), parameters 125-13-5-2-25-32, из CBN with CBN grit size B54, with resin bond: **5-0086 12V5-20 125-13-5-2-25-32 B54 B9-00 PREMIUM**

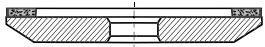
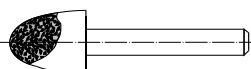
Other specifications and sizes are available on request.

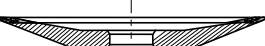
## WHEELS SHAPES IN OUR PRODUCT LINE

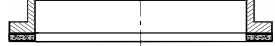
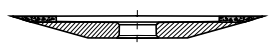
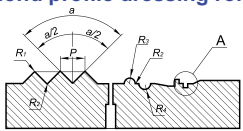
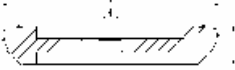
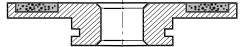
Item	Item	Item	Item
<p><b>1A1</b> Straight grinding wheels</p> 	<p><b>6A2T</b> Flat grinding wheels</p> 	<p><b>12D9</b> Dish grinding wheels</p> 	<p><b>14F6V</b> Flat grinding wheels with semicircular-concave profile</p> 
<p><b>14A1</b> Straight flat grinding wheels</p> 	<p><b>6A9</b> Recessed flat grinding wheels</p> 	<p><b>12V9-45</b> Cup grinding wheels</p> 	<p><b>1F6V</b> Flat grinding wheels with semicircular-concave profile</p> 
<p><b>3A1</b> Straight grinding wheels</p> 	<p><b>12A2-45</b> Cup grinding wheels</p> 	<p><b>11V9-70</b> Cup grinding wheels</p> 	<p><b>2F6V</b> Flat grinding wheels with semicircular-concave profile</p> 
<p><b>9A3</b> Flat grinding wheels with double sided recess</p> 	<p><b>12A2-20</b> Dish grinding wheels</p> 	<p><b>1FF1</b> Flat grinding wheels with semicircular convex profile</p> 	<p><b>1DD6V</b> Diamond wheels for glass processing</p> 
<p><b>14U1</b> Three-sided grinding wheels</p> 	<p><b>12V5-45</b> Cup grinding wheels</p> 	<p><b>14FF1</b> Grinding wheels with semicircular convex profile</p> 	<p><b>6A2</b> Flat recessed diamond grinding wheels</p> 
<p><b>1V1</b> Grinding wheels</p> 	<p><b>12V5-20</b> Dish grinding wheels</p> 	<p><b>AW</b> Cylindrical diamond mounted points</p> 	<p><b>1EE1</b> Flat grinding wheels with double-sided conical profile</p> 
<p><b>1A1R</b> Cutting wheels</p> 	<p><b>4A2</b> Dish grinding wheels</p> 	<p><b>F1W</b> Vaulted diamond mounted points</p> 	<p><b>14EE1</b> Flat grinding wheels with double-sided conical profile</p> 
<p><b>6A2</b> Recessed flat grinding wheels</p> 	<p><b>12R4</b> Dish grinding wheels</p> 	<p><b>EW</b> Conical diamond mounted points</p> 	<p><b>2A2</b> Ring wheels</p> 
<p><b>4B2</b> Dish grinding wheels</p> 	<p><b>Diamond profile dressing rollers</b></p> 	<p><b>Wheels for sharpening band saws for wood</b></p> 	<p><b>1A2</b> Flat grinding wheels</p> 

## QUESTIONNAIRE

**for selecting PREMIUM wheels made by PrJSC "POLTAVA DIAMOND TOOLS"**

**Contact information:**

Company name: \_\_\_\_\_  
 Company address: \_\_\_\_\_  
 Contact person: \_\_\_\_\_  
 Tel.: \_\_\_\_\_ Fax: \_\_\_\_\_ e-mail: \_\_\_\_\_

**Characteristics of the grinding wheel currently used:**

Manufacturer	Wheel shape	Wheel size (DxTxXxH mm)	Diamond grit size	Bond type	Catalog number
_____	_____	_____ X X X _____	_____	_____	_____

Wheel life, number of workpieces per shift: \_\_\_\_\_  
 Approximate number of wheels used annually: \_\_\_\_\_  
 Type and make of equipment  
 the wheel is used on: \_\_\_\_\_

**Grinding parameters**

Grinding type	Grinding depth, mm	Peripheral velocity, m/sec.	Line feed mm/min.	Cross feed, mm/min	With/without coolant (brand and type of coolant)
Tool sharpening					
Tool manufacturing					
Saw sharpening					
Face grinding					
Circular external					
Circular internal					
Other _____					

**Workpiece material:**

Tungsten carbide (brand and type): \_\_\_\_\_  
 High speed steel (brand and type): \_\_\_\_\_  
 Other material: \_\_\_\_\_

**Type of abrasive used for dressing:** \_\_\_\_\_

**Please send the completed questionnaire to us at:**

Fax: +38 (0532) 503820, 503821  
 e-mail: pdt@poltavadiamond.com.ua

A series of horizontal dashed lines spanning the width of the page, intended for writing notes.





**PrJSC "POLTAVA DIAMOND TOOLS"**

e-mail: [pdt@poltavadiamond.com.ua](mailto:pdt@poltavadiamond.com.ua)

[www.pdt.tools](http://www.pdt.tools)

**Our official representative:**

Tel.:

Fax:

e-mail:



Quality  
Management  
System  
ISO 9001

EN 13236