

CONTENTS



1

기업소개

COMPANY PROFILE



2

제품소개

PRODUCT
INTRODUCTION

1

기업소개
COMPANY PROFILE

생산설비

AUTOMATION

자동화 생산설비



완벽한 검사장비

TEST-EQUIPMENT

검사장비



배터리 완성 된
테스트 기기



반제품 배터리
테스트 장비



보호 보드 테스트
장비



배터리 노화 장비



부압 시험기

2

제품소개

PRODUCT INTRODUCTION

목차

Series 1 : 이륜차
Two-wheeled vehicle

킥보드
슈퍼 킥보드
전기자전거
전기차
전기모토싸이클

Scooters
Super Scooter
Electric bikes
Electric vehicle
Electric motorcycle

Series 2 : 특수차량
Special vehicle

물류차량
AGV
군용견인차
어선추진동력시스템

Logistics vehicles
Automated Guided Vehicle
Military tractors
Fishing vessel propulsion power system

Series 3 : ESS
Energy storage

보조배터리
가정용보조배터리
통신보조배터리
소형 보조배터리

Portable energy storage
Home energy storage systems
Communication energy storage
Small energy storage

Series 4 : Smart Home
Smart home

전동커튼
청소기
자동문

Electric curtains
vacuum cleaner
Automatic doors

Series 1

이륜차

Two-wheeled vehicle

킥보드

Scooters

슈퍼킥보드

Super Scooter

전기자전거

Electric bikes

전기차

Electric vehicle

전기모토싸이클

Electric motorcycle

제품소개

PRODUCT INTRODUCTION

킵보드 Scooters

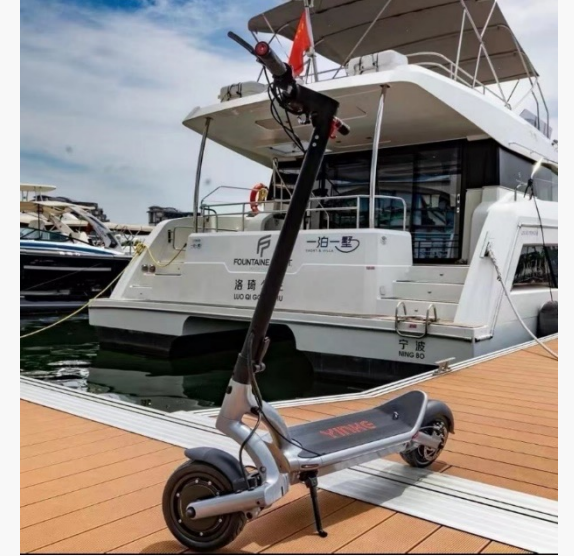
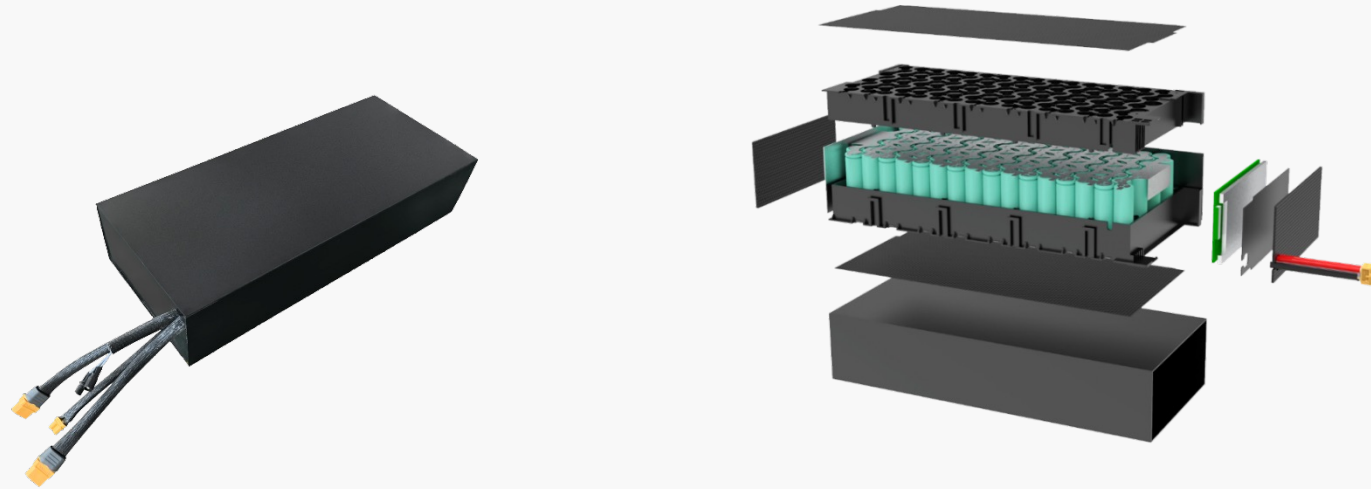

57.6V25.6AH

스팩/Size: 345*146*72MM

팩 방식/Connection Type: 16S8P

셀 수량/Cells:128PCS

셀 모델/Model: 18650

방수등급/IP: IPX6

중량/Weight:7.5KG

방전전류/Discharge Current: 60A

모듈 내부 ABS+PC난연재질 및 일체화 스탠드를 사용하여 견고. 미관. 진동 방지. 모듈 케이스는 내충격 구조의 알루미늄 합금 하우징을 사용하여 안전 보장 가능.

BMS 기능이 완벽하며 역충전보호, 충방 전고 저온 보호 및 저전압과 쇼트 보호 가능.



PART TWO

킥보드 Scooters



36V15.6AH

스팩/Size: 420*120*78MM

조립방식/Connection Type: 10S6P

셀수량/Cells:60PCS

셀모델/Model: 18650

방수등급/IP: IPX7

중량/Weight:4.8KG

방전전류/Discharge Current: 30A

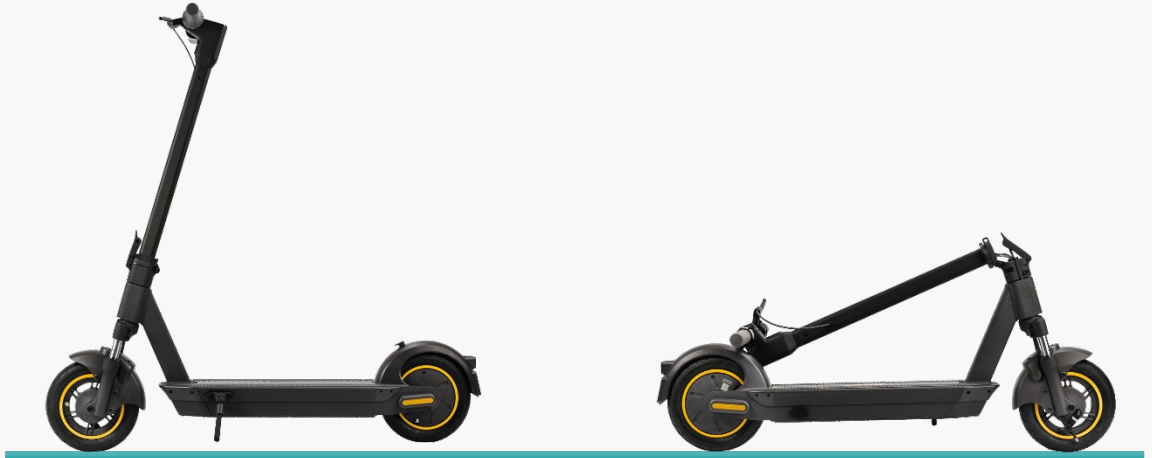

슈퍼킥보드 Super Scooter

DY-YK01

72V40AH

스팩/Size:	530*252*100MM
조립방식/Connection Type:	20S8P
셀수량/Cells:	160PCS
셀모델/Model:	21700
방수등급/IP:	IPX7
중량/Weight:	17KG
방전전류/Discharge Current:	160A



슈퍼킥보드 Super Scooter

DY-YH01

57.6V40AH

스팩/Size:	465*228*86MM
조립방식/Connection Type:	16S8P
셀수량/Cells:	128PCS
셀모델/Model:	21700
방수등급/IP:	IPX7
중량/Weight:	15KG
방전전류/Discharge Current:	100A

도면/Cells Layout

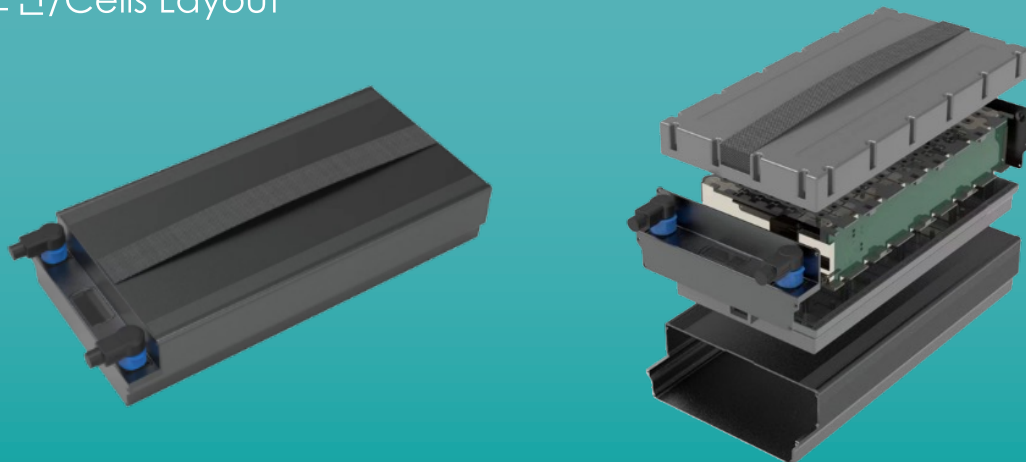

CM-RA

전기자전거 Electric bikes

DY-JQ01

36V10AH

스팩/Size: 580*52*52MM

조립방식/Connection Type: 10S2P

셀수량/Cells: 20PCS

셀모델/Model: 21700

방수등급/IP: IPX7

중량/Weight: 2.1KG

방전전류/Discharge Current: 18A

도면/Cells Layout



Line 700C Gravel e-bike

전기차 Electric vehicle

DY-NA01

48V12AH

스팩/Size: 265*183*155MM

조립방식/Connection Type: 16S5P

셀수량/Cells: 80PCS

셀모델/Model: 26700 나트륨 cell

방수등급/IP: IPX6

중량/Weight: 7KG

방전전류/Discharge Current: 30A

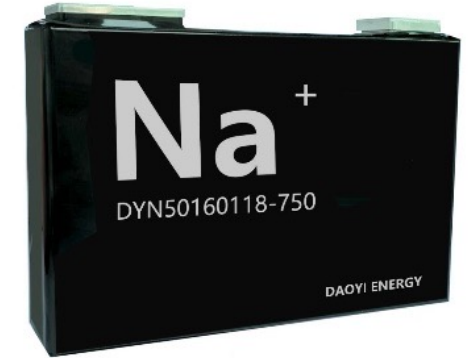

나트륨 cell

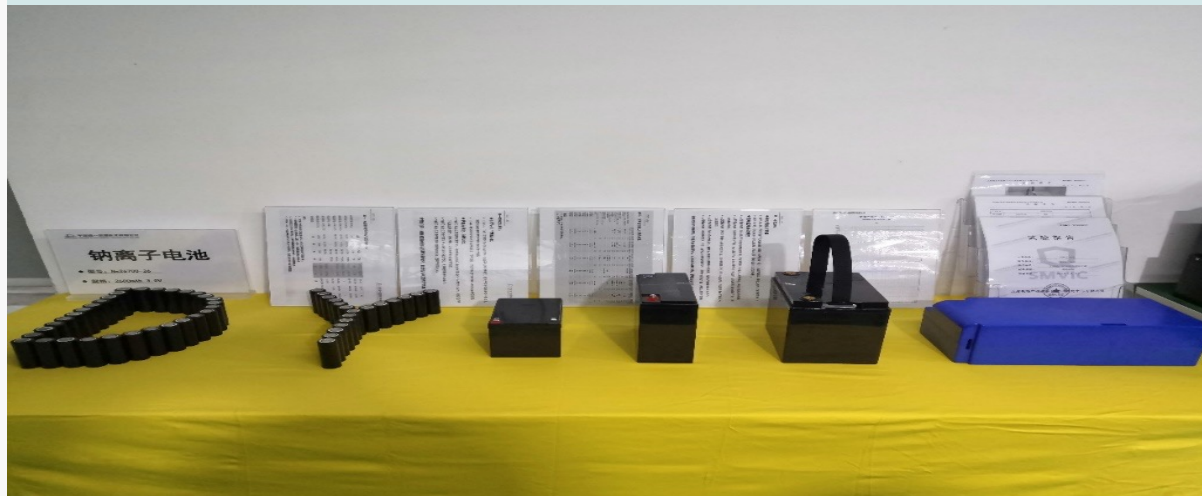

전기모토싸이클 Electric motorcycle

DY-YF01

72V40AH

스팩/Size: 380*170*150MM

조립방식/Connection Type: 20S8P

셀수량/Cells: 160PCS

셀모델/Model: 21700

방수등급/IP: IPX7

중량/Weight: 13.5KG

방전전류/Discharge Current: 200A



Series 2

특수차량
Special vehicle

물류차량

Logistics vehicles

AGV

Automated Guided Vehicle

군용견인차

Military tractors

어선추진동력시스템

Fishing vessel propulsion power system

제품소개

PRODUCT INTRODUCTION

물류차량 Logistics vehicles

DY-SJ01

48V30AH

스팩/Size: 425*120*82MM

조립방식/Connection Type: 13S6P*2

셀수량/Cell:78*2PCS

셀모델/Model: 21700

방수등급/IP: IPX7

중량/Weight:7.5KG*2

방전전류/Discharge Current : 40A

도면/Cells Layout

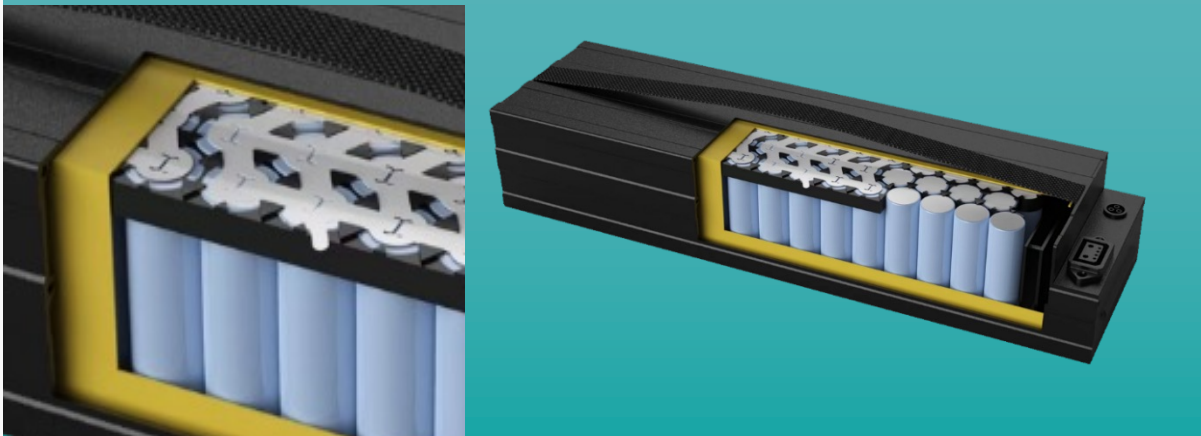

Cargo

PART TWO

AGV Automated Guided Vehicle

DY-SZ01

图示/Cells Layout

48V48AH

스팩/Size:	300*255*155MM
조립방식/Connection Type:	16S12P
셀수량/Cells:	192PCS
셀모델/Model:	26700
방수등급/IP:	IPX7
중량/Weight:	25KG
방전전류/Discharge Current:	80A

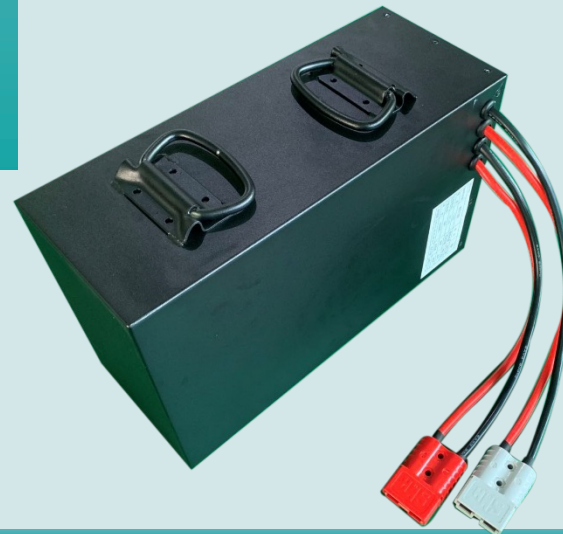

군용견인차 Military tractors

DY-HT20601

25.2V35AH

스팩/Size:	300*250*50MM
조립방식/Connection Type:	7S10P
셀수량/Cells:	70PCS
셀모델/Model:	18650
방수등급/IP:	IPX7
중량/Weight:	5KG
방전전류/Discharge Current:	40A

图示/Cells Layout

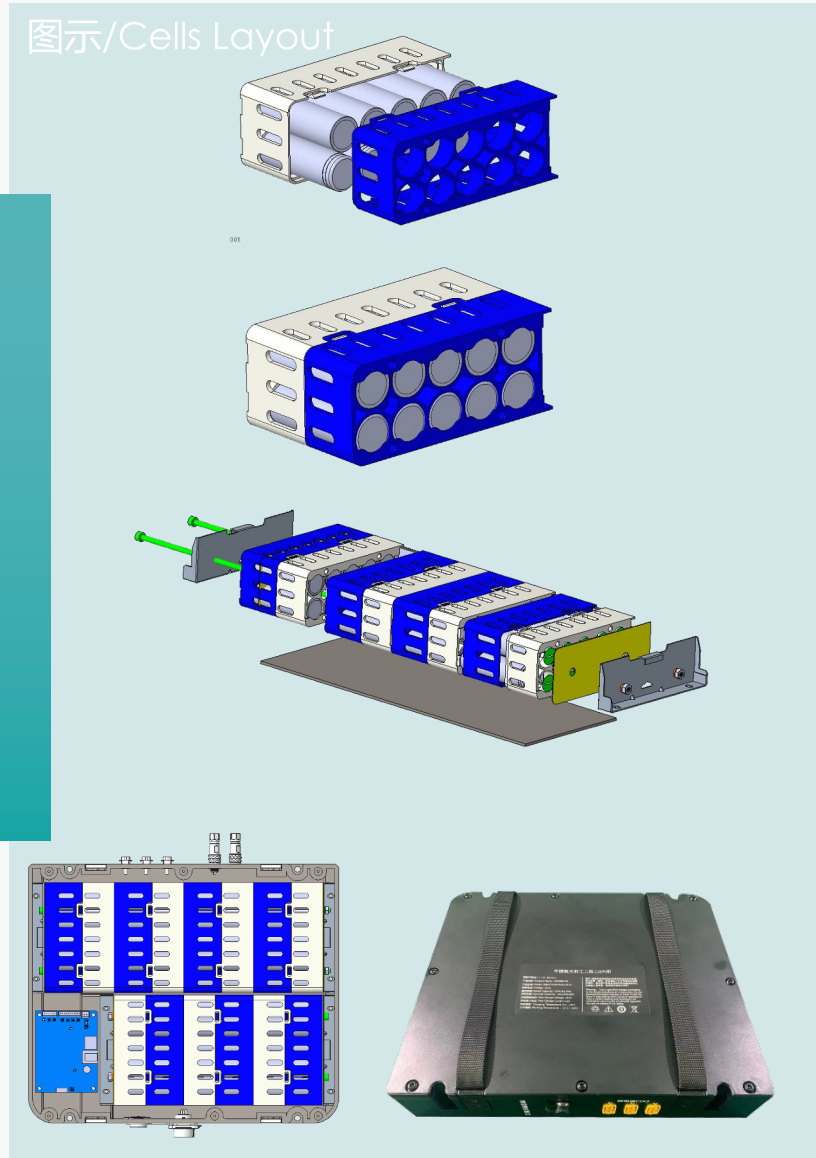

어선추진동력시스템 Fishing vessel propulsion power system

DY-HB01

102.4V200AH

- 스팩/Size: 460*420*135MM (单体)
- 조립방식/Connection Type: 8S2P*4
- 셀수량/Cells: 16*4PCS
- 셀모델/Model: 각형 cell
- 방수등급/IP: IPX6
- 중량/Weight: 45KG (单体)
- 방전전류/Discharge Current: 300A

图示/Cells Layout



어선추진기



Series 3

ESS
Energy storage

보조배터리

Portable energy storage

가정용 보조배터리

Home energy storage systems

통신 보조배터리

Communication energy storage

소형 보조배터리



Small energy storage

제품소개

PRODUCT INTRODUCTION

PART TWO

보조배터리 Portable energy storage

DY1200	칼러	수출공용	용량	용량	중량	Data	부품	
	검은색 밋 춤형 색상	1200W	1216Wh	63.36Ah	G.W.: 16.4Kg N.W.: 14.4Kg	사이즈	367*210*270mm	차량 충전 연결선/태양 광 충전 어댑터 케이블/AC 충전 케이블/제품 설명서/자격 증/무상수리 카드
						입력:	1200W	
PD입력:	20V-3.5A (최고5A/PD100W어댑터)							
태양열/DC입력:	18V-20A (Max400W)							
병렬 기능:	다중 병합/AC병렬							
충전구/DC출력 포트:	12V-10A							
AC출력:	110V/220V/50Hz/60Hz/계속1200W/최고치2400W							
AC정격 출력 에너지:	1095Wh							
USB출력 포트:	5V-2A/QC3.0-18W							
USB출력 포트:	FCP/QC3.0/QC2.0/Apple mode/AFC/BC1.2							
TYPE-C출력 포트:	5V/9V/12V/15V/20V/3A/5A							
TYPE-C출력 포트:	PD2.0/PD3.0/QC2.0/QC3.0/QC3+/FCP/AFC/SCP/Apple							
무선 충전:	Max15W							
무선 충전계약:	WPC1.2.4 EPP계약							
배터리:	리튬인산철							
순환 횟수:	≥3000							
사용 온도:	-10~60°C							
충전 온도:	0~45°C							
시스템 보호:	과충전 보호/과다 복용 방전 보호/과전류 보호/과열 보호/단락 보호/과전압 보호							
제품 내부 상자 크기:	408*313*300mm							
액세서리 박스 크기:	250*200*45mm							
제품 포장 크기:	422*327*344mm							
인증서:	PSE/IEC62133배터리 보고서/METI등록/UN38.3/MSDS/ROHS/CE/EMC/LVD/FCC/해 상 및 항공 화물 감정서/낙하 테스트 보고서							
다른 기능:	조명등/탈부착식 손전등/탈착식 보조 배터리 구성 요소							
								

가정용 보조배터리 Home energy storage systems

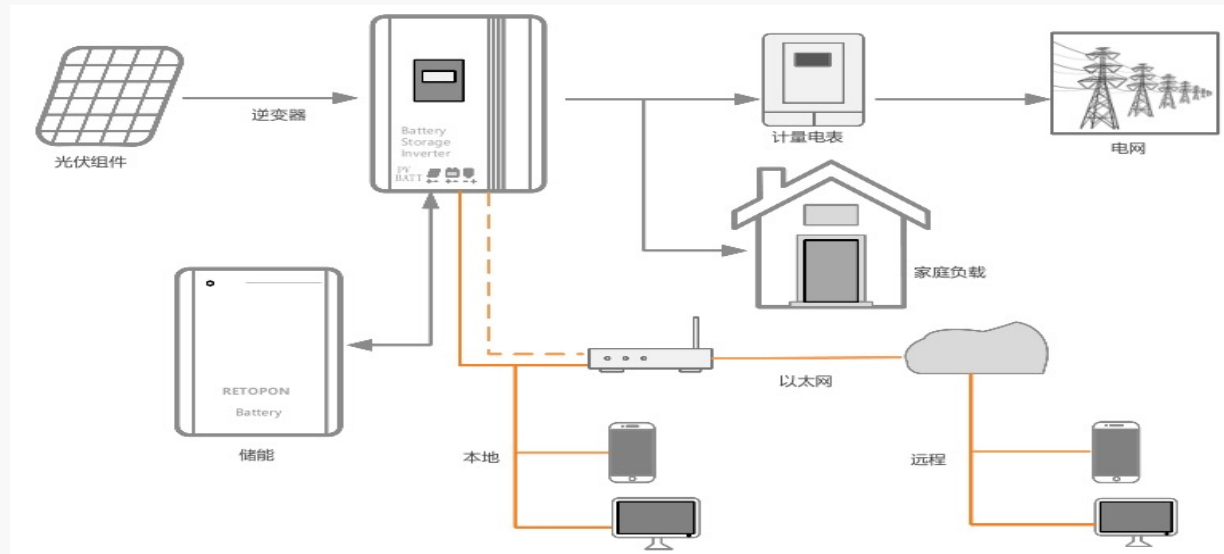

51.2V100AH

스팩/Size: 660*460*180MM
 조립방식/Connection Type: 16S1P
 셀 수량/Cell:16PCS
 셀 모델/Model: 方形铝壳
 Cycle: 6000
 Nominal Energy: 5.1KWH
 방전전류/Discharge Current : 100A

가정용 Smart 에너지 네트워크:

고효율 태양광 패널, DC-AV inverter, DYPOWER1 배터리 통합 에너지 저장 시스템을 구성하여 가구 내 전기에너지 저장 사용 또는 전력 네트워크에 연결하여 저장된 에너지를 역으로 판매가 가능하며 지능적으로 전력부하 고봉시 방전, 전력부하 저곡시 충전으로 조절할 수가 있다. 에너지 및 비용 절약 목적과 응급 전원 기능을 고려한 시스템으로 설치가 편리하고 사용에 안전하다.



10KW

15KW

20KW

통신용 보조 배터리 Communication energy storage

48V100Ah



스펙	Data	비고
SIZE (mm)	440*400*132(3U)	
셀 유형	LFP 각형배터리	
연결방식	15S1P	
정격전압/V	48	
정격용량/Ah	100	
Cut-off 방전전압/V	43.5	
Cut-off 충전전압/V	52.5~54	
Max 방전전류/A	100	
Max 지속방전전류/A	100	
충전온도/°C	0~55	
방전온도/°C	-20~60	
저장온도/°C	-5~45	
작동온도	5~95% RH	
작동해발	< 4000m	
통신방식	RS232, RS485, CAN	
IP 등급	IP54	
중량/KG	43±0.5	

통신용 보조 배터리 Communication energy storage

48V150Ah



스펙	Data	비고
size (mm)	440*480*222(5U)	
셀 유형	LFP 각형배터리	
연결방식	15S1P	
정격전압/V	48	
정격용량/Ah	150	
Cut-off 방전전압/V	43.5	
Cut-off 충전전압/V	52.5~54	
Max 방전전류/A	100	
Max 지속방전전류/A	100	
충전온도/°C	0~55	
방전온도/°C	-20~60	
저장온도/°C	-5~45	
작동온도	5~95% RH	
작동해발	<4000m	
통신방식	RS232, RS485, CAN	
IP 등급	IP54	
중량/KG	66±0.5	

통신용 보조배터리 Communication energy storage

48V200Ah



스펙	Data	비고
size (mm)	440*550*222(5U)	
셀 유형	LFP 각형 배터리	
연결방식	15S1P	
정격전압/V	48	
정격용량/Ah	200	
Cut-off 방전전압/V	43.5	
Cut-off 충전전압/V	52.5~54	
Max 방전전류/A	100	
Max 지속방전전류/A	100	
충전온도/°C	0~55	
방전온도/°C	-20~60	
저장온도/°C	-5~45	
작동온도	5~95% RH	
작동해발	< 4000m	
통신방식	RS232, RS485, CAN	
IP 등급	IP54	
중량/KG	78±0.5	

PART TWO

소형 보조 배터리 Small energy storage

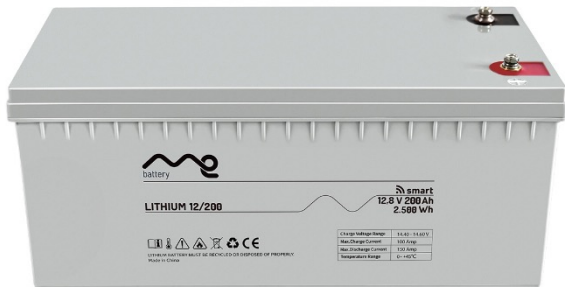

모델	DY12150	DY12180	DY12200	DY12240
정격전압	12.8V	12.8V	12.8V	12.8V
작동전압	10.8V~14.6V	10.8V~14.6V	10.8V~14.6V	10.8V~14.6V
정격용량	150Ah	180Ah	200Ah	240Ah
최대지속충전전류	100A	100 A	100 A	100A
최대지속방전전류	100A	100A	100 A	100A
Cycle /80%DOD	3000C	3000C	3000C	3000C
Size(LWH)mm	520*270*220	520*270*220	520*270*220	520*270*220
중량(Kg)	31.5	31.5	31.5	31.5
IP 등급	IP65	IP65	IP65	IP65
단자유형	M8	M8	M8	M8
연결방식	4S/4P	4S/4P	4S/4P	4S/4P

모델	DY1208	DY1212	DY 1220	DY1236	DY 1250
정격전압	12.8V	12.8V	12.8V	12.8V	12.8V
작동전압	10.8V~14.6V	10.8V~14.6V	10.8V~14.6V	10.8V~14.6V	10.8V~14.6V
정격용량	8Ah	12Ah	20Ah	36Ah	50Ah
최대지속충전전류	8A	12A	20A	36A	50A
최대지속방전전류	8A	12A	20A	36A	50A
Cycle /80%DOD	3000C	3000C	3000C	3000C	3000C
Size(LWH)mm	151*65*94	151*65*94	181*77*170	197*165*170	223*150*178
중량(Kg)	0.95	1.4	2.3	4.5	5.6
IP 등급	IP65	IP65	IP65	IP65	IP65
단자유형	F2	F2	M5	M6	M6
연결방식	4P	4P	4P	4P	4P

Series 4

스마트 홈
Smart home

전기커튼

Electric curtains

청소기

vacuum cleaner

자동문

Automatic doors

제품소개

PRODUCT INTRODUCTION

PART TWO

전동커튼 Electric curtains

DY-SR(01-03)

	3.6V	7.2V	11.1V
스팩/Size:	70*19.5MM	135*19.5MM	200*19.5MM
조립방식/Connection Type:	单颗	2S	3S
셀 수량/Cells:	1PCS	2PCS	3PCS
셀 모델/Model:	14/18/21	14/18/21	14/18/21
방수등급/IP:	IPX7	IPX7	IPX7
중량/Weight:	50G	100G	150G
방전전류/Discharge Current:	3A	3A	3A

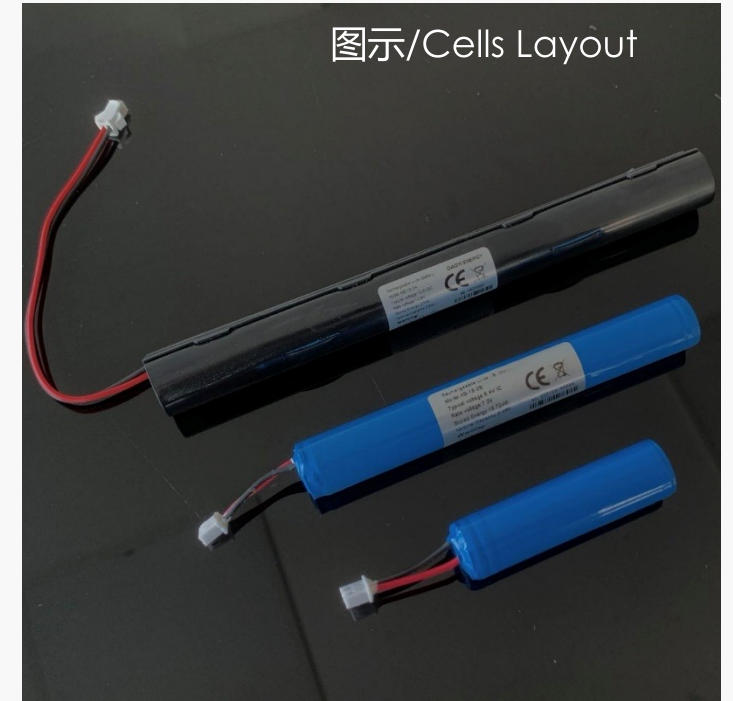

PART TWO

청소기 vacuum cleaner

DY-JR01

36V10.4AH

스팩/Size:	195*160*135MM
조립방식/Connection Type:	10S4P
셀 수량/Cells:	40PCS
셀 모델/Model:	18650
방수등급/IP:	IPX5
중량/Weight:	3KG
방전전류/Discharge Current:	15A



Layout

자동문 Automatic doors

DY-AD01

21.6V3.3AH

스팩/Size:	\
조립방식/Connection Type:	6S
셀 수량/Cells:	6PCS
셀 모델/Model:	18650
방수등급/IP:	IPX5
중량/Weight:	360G
방전전류/Discharge Current:	10A



图示/Cells Layout

