

## Shock protection and safeguards in photovoltaic installations (example solutions)

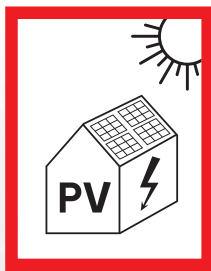

*Divides energy, multiplies solutions!*

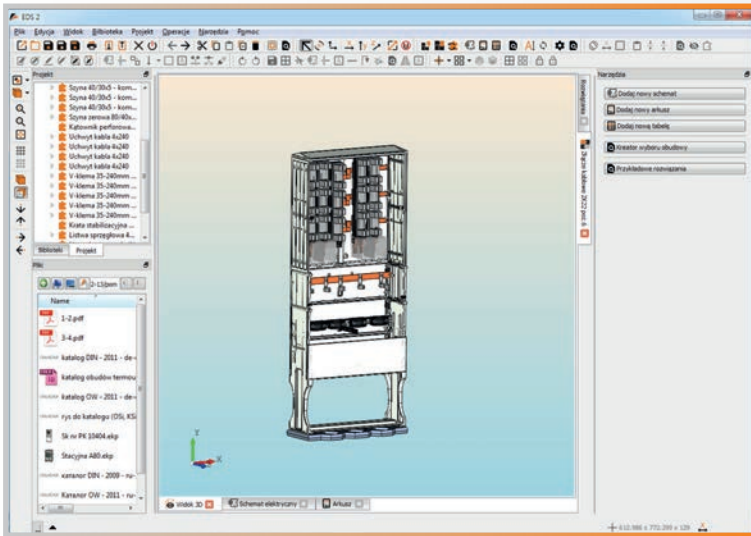

EDS is an application designed by the EMITER company. It is intended to be used for designing electrical switchgear. The software is available on CD-R and downloadable from eds.emiter.com.

- switchgear design
- electric scheme creation
- datasheet and printouts creation
- export to DXF and PDF format
- software and library updating system

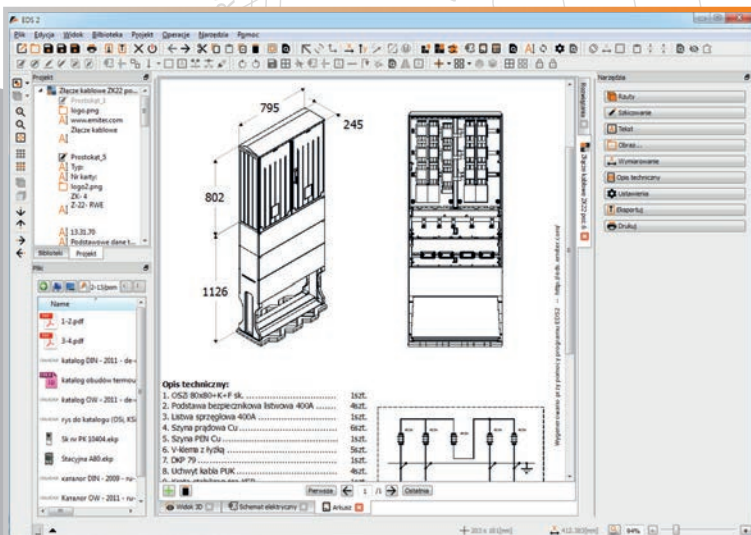
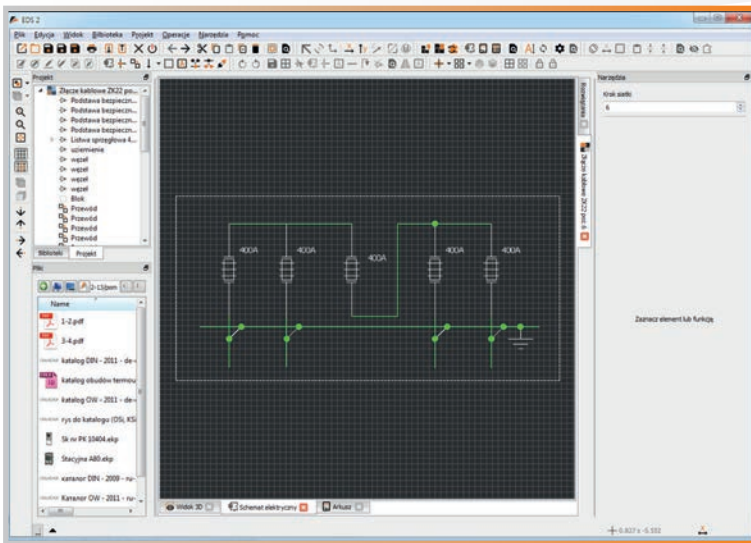

Photovoltaic systems, as well as all other electrical installations and devices are exposed to various types of interference. They can be caused by shades, obscurations, or damage to one or more panels, lightning strike near the installation or directly into the installation and other overvoltages arising in photovoltaic and control installation.

Therefore, a properly made photovoltaic installation should contain, except of basic protection (against the direct contact), an additional protection against:

- overvoltages and couplings of the DC and AC sides
- overloads and short-circuit effects on the DC side.

In order to protect photovoltaic installation and electronic devices connected to it, we designed specialized switchgears using:

- surge arresters (SPD) type 1, type 2, type 1+ type 2
- overcurrent breakers
- fuse switches
- additionally an automatic fire protection switch
- protection enclosures class II in our production
- additional accessories enabling the switchgears to be install on: an energy post, building wall and structural support elements of pv panels.

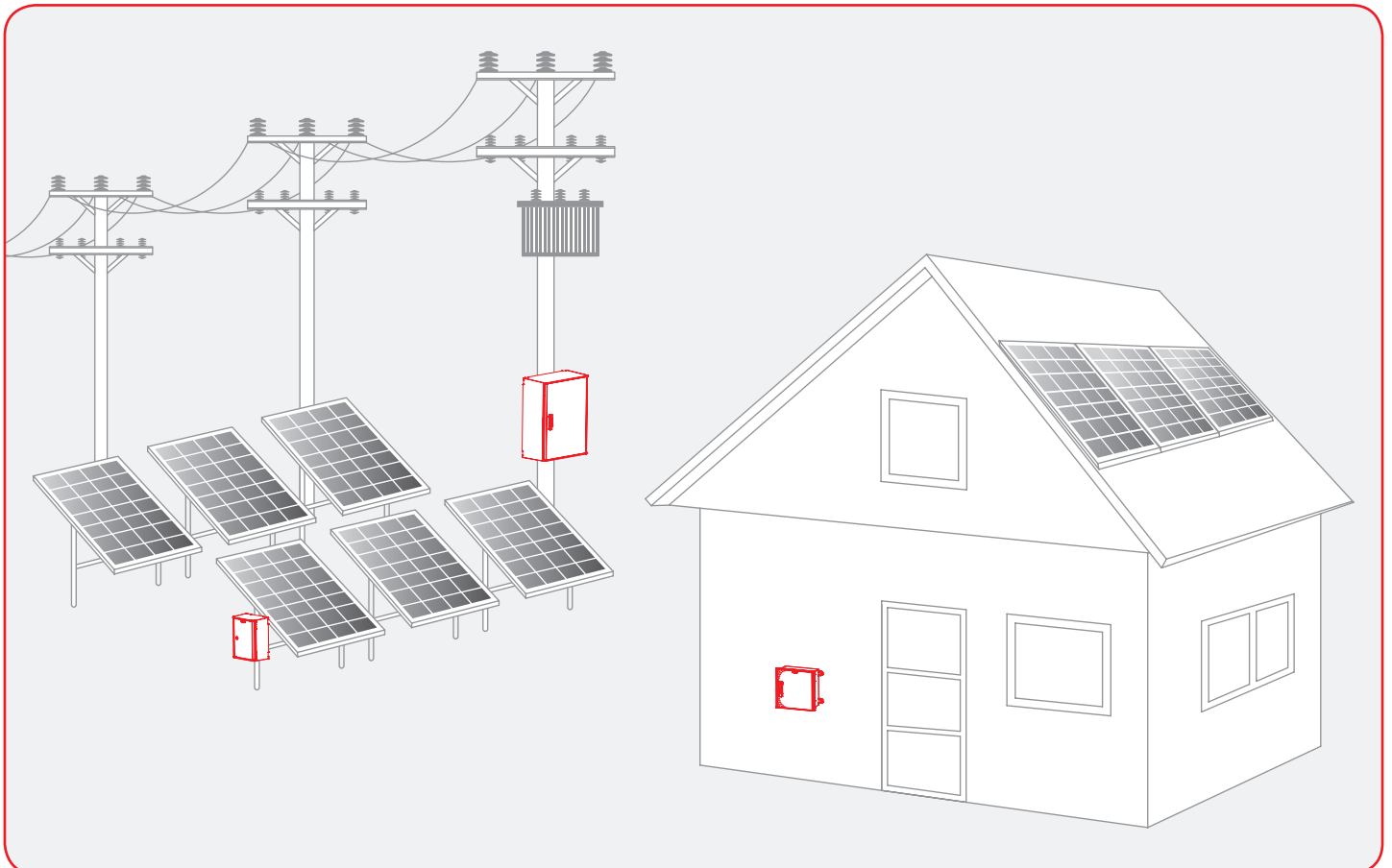

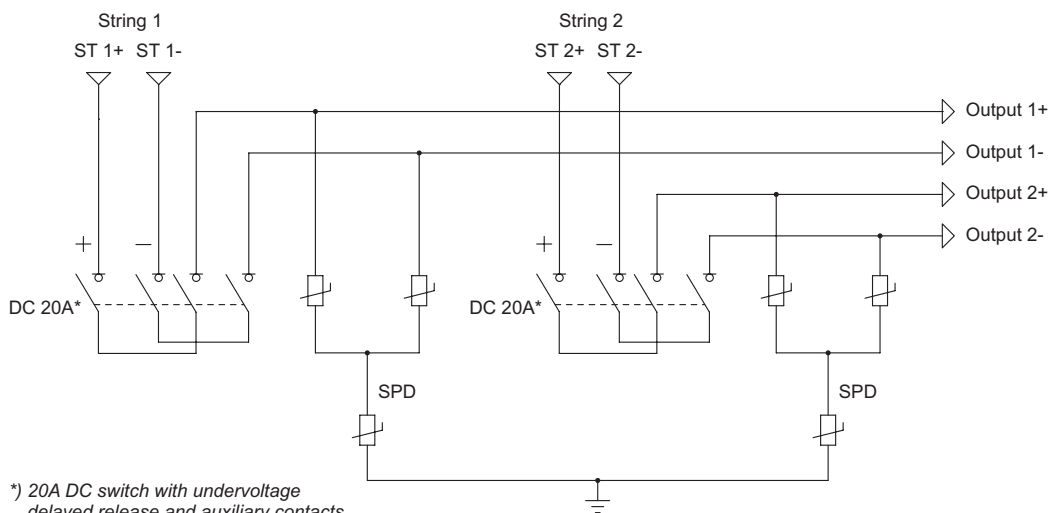
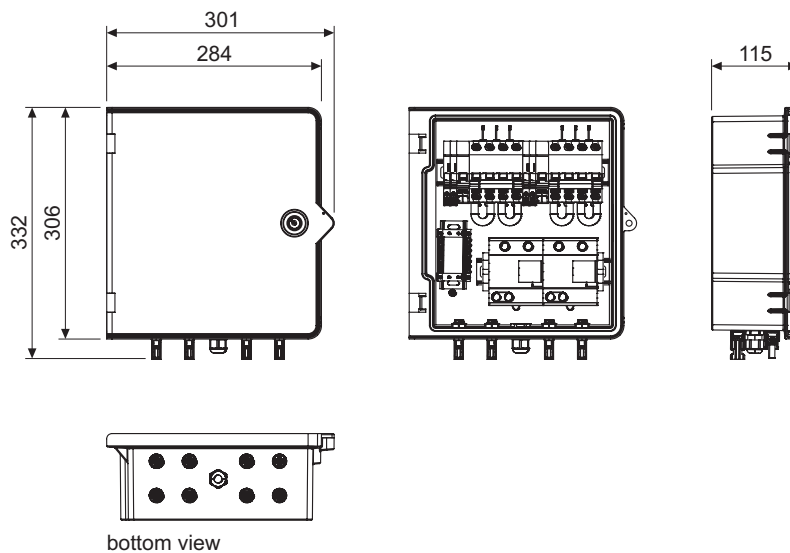

\*) 20A DC switch with undervoltage delayed release and auxiliary contacts 1 NO, 1 NC

**Technical data**

**Installation**

Wall mounting	
Post mounting	Mount: HL6 K3

**Enclosure**

Type	LILA 3366
Isolating material	Glass fiber reinforced polyester
Protection grade IP	IP66
Impact resistance	IK10
Protection class	II
Colour	RAL 7035

**Electrical parameters (DC)**

Surge protection class	T1+T2 (B+C)
Total discharge current (10/350 μs) (I <sub>total</sub> )	12,5 kA
Surge current (10/350 μs) (I <sub>imp</sub> )	6,25 kA
Maximum discharge current (8/20 μs) (I <sub>max</sub> )	40 kA
Voltage protection level (U <sub>p</sub> )	≤ 3,8 kV
Maximum working voltage (U <sub>c</sub> )	1000 V

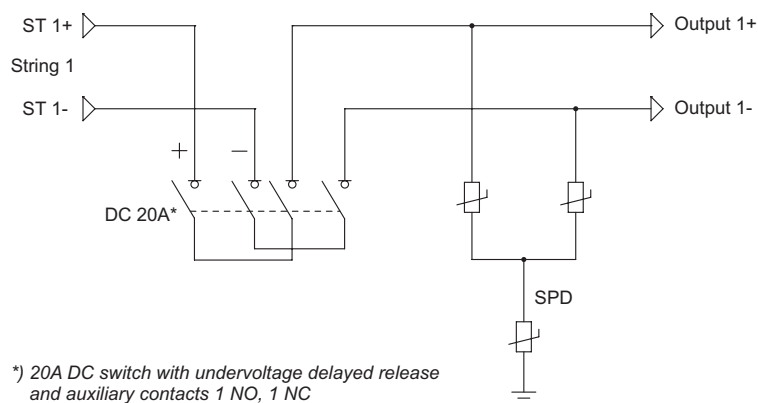
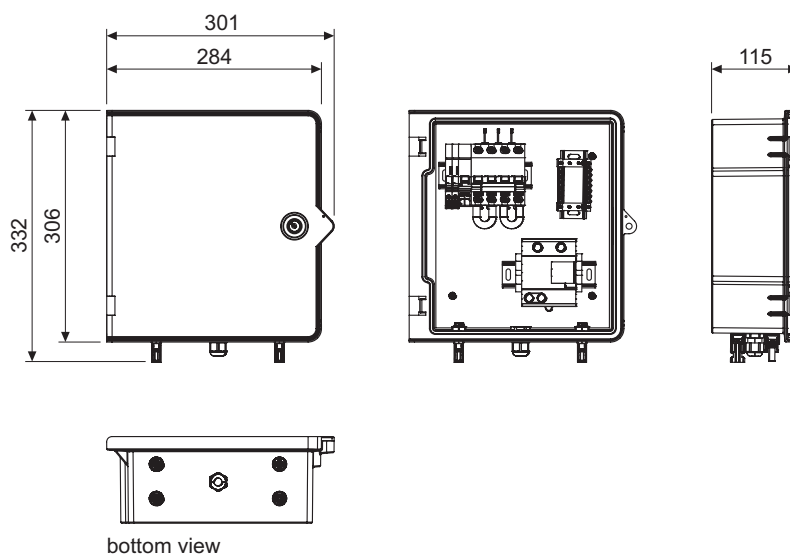

**Technical data**

**Installation**

Wall mounting	
Post mounting	Mount: HL6 K3

**Enclosure**

Type	LILA 3366
Isolating material	Glass fiber reinforced polyester
Protection grade IP	IP66
Impact resistance	IK10
Protection class	II
Colour	RAL 7035

**Electrical parameters (DC)**

Surge protection class	T1+T2 (B+C)
Total discharge current (10/350 $\mu$ s) ( $I_{total}$ )	12,5 kA
Surge current (10/350 $\mu$ s) ( $I_{imp}$ )	6,25 kA
Maximum discharge current (8/20 $\mu$ s) ( $I_{max}$ )	40 kA
Voltage protection level ( $U_p$ )	$\leq 3,8$ kV
Maximum working voltage ( $U_c$ )	1000 V

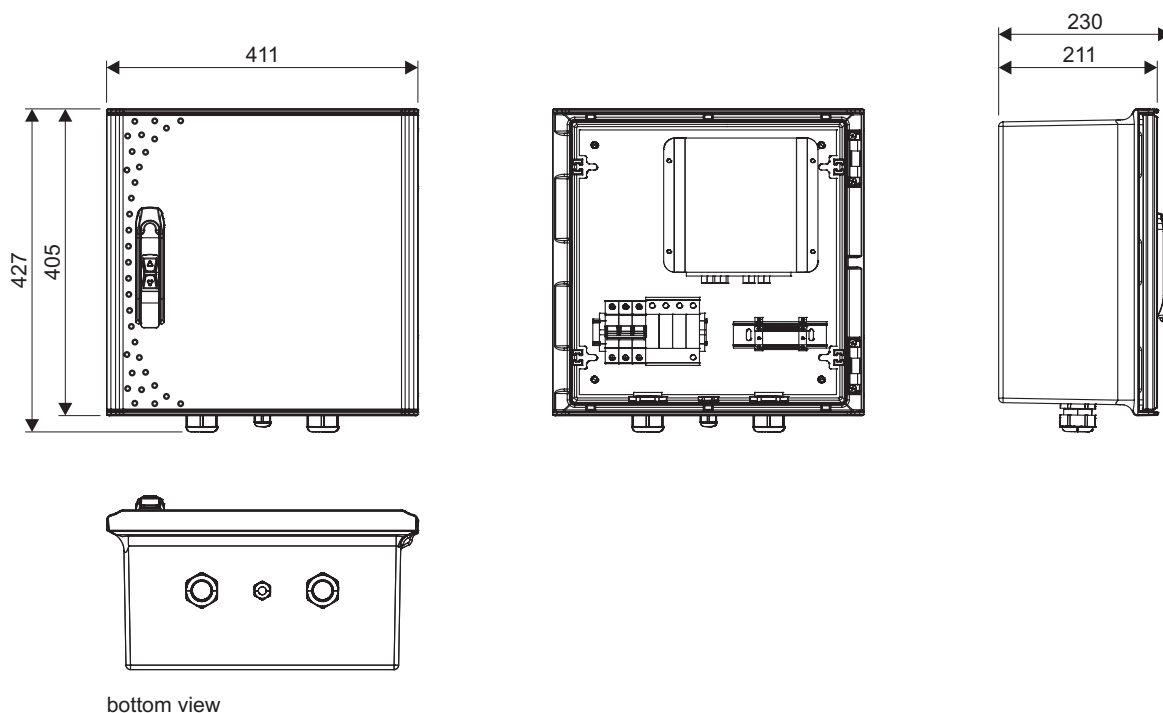

bottom view

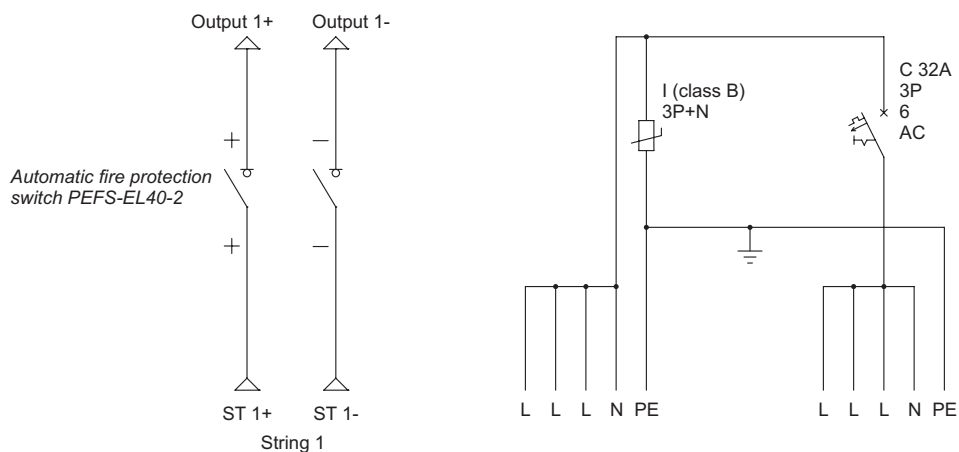

Technical data

Installation

Wall mounting	Mount: UMO K3
Post mounting	Mount: UN K3, UPN K3

Enclosure

Type	LILA 4466
Isolating material	Glass fiber reinforced polyester
Protection grade IP	IP66
Impact resistance	IK10
Protection class	II
Colour	RAL 7035

Electrical parameters (AC)

Surge protection class	T1+T2 (B+C)
Surge current (10/350 μs) (I <sub>imp</sub> )	12,5 kA
Maximum discharge current (8/20 μs) (I <sub>max</sub> )	50 kA
Voltage protection level (U <sub>p</sub> )	≤ 1,5 kV
Maximum working voltage (U <sub>c</sub> )	255 V
Overcurrent protection	3P C32A iC60

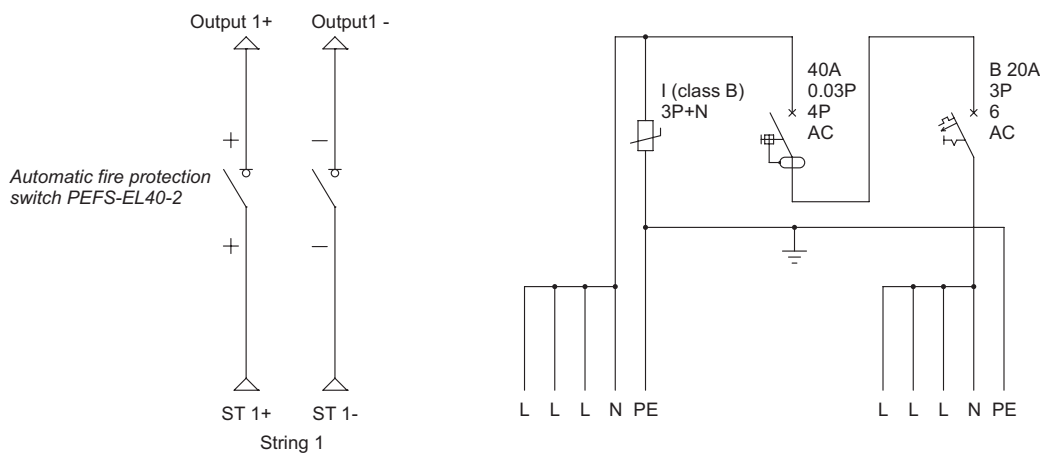
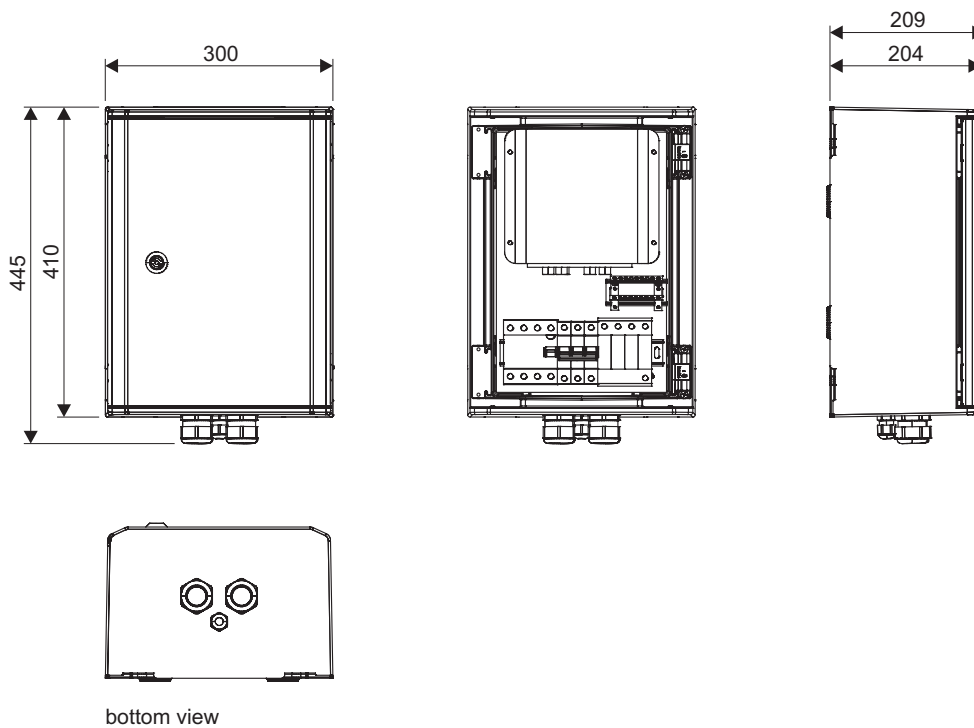

**Technical data**

**Installation**

Wall mounting	Mount: UMO K3
Post mounting	Mount: UN K3, UPN K3

**Enclosure**

Type	HYDRA 345
Isolating material	Glass fiber reinforced polyester
Protection grade IP	IP65
Impact resistance	IK10
Protection class	II
Colour	RAL 7035

**Electrical parameters (AC)**

Surge protection class	T1+T2 (B+C)
Surge current (10/350 μs) (I <sub>imp</sub> )	12,5 kA
Maximum discharge current (8/20 μs) (I <sub>max</sub> )	50 kA
Voltage protection level (U <sub>p</sub> )	≤ 1,5 kV
Maximum working voltage (U <sub>c</sub> )	255 V
Overcurrent protection	3P C32A iC60
Residual current protection	40A 4-pole 300mA

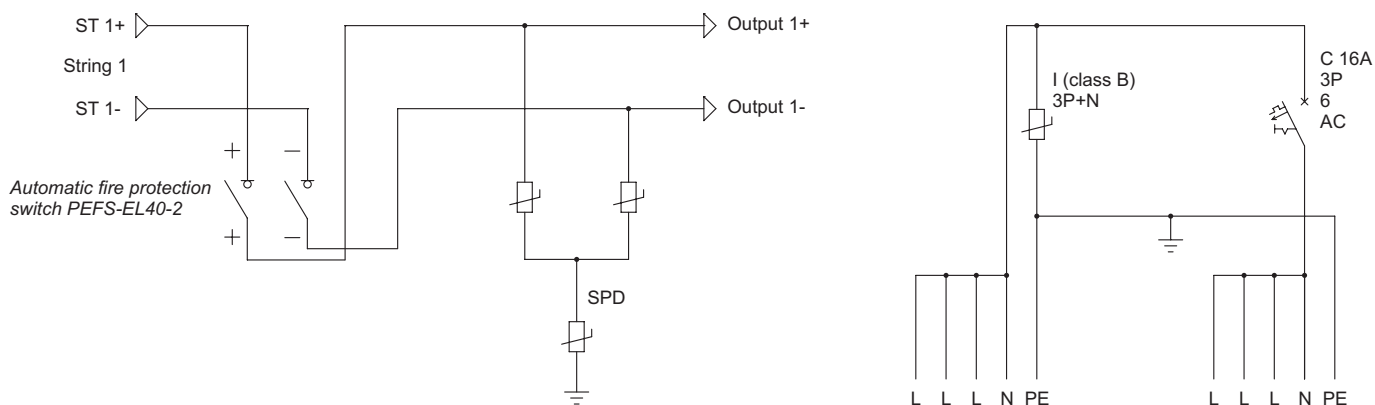
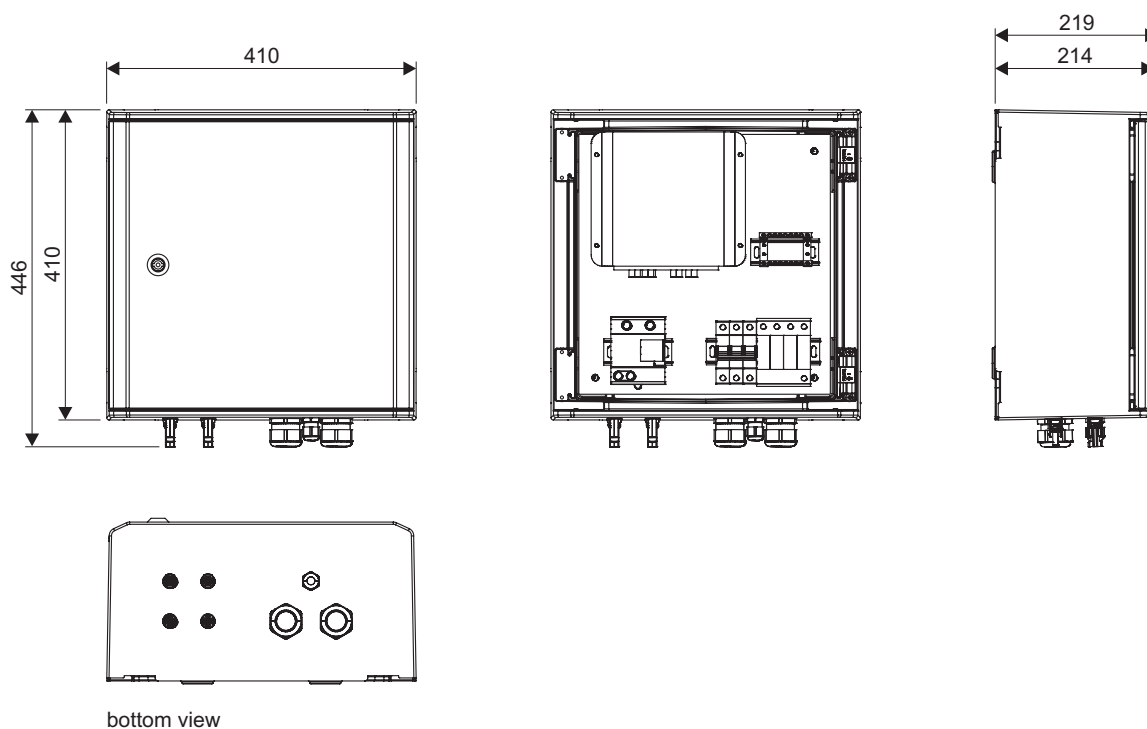

**Technical data**

**Installation**

Wall mounting	Mount: UMO K3
Post mounting	Mount: UN K3, UPN K3

**Enclosure**

Type	HYDRA 445
Isolating material	Glass fiber reinforced polyester
Protection grade IP	IP65
Impact resistance	IK10
Protection class	II
Colour	RAL 7035

**Electrical parameters (DC)**

Surge protection class	T2 (C)
Short-circuit resistance ( $I_{SCPV}$ )	10 kA
Total discharge current (8/20 $\mu$ s) ( $I_{total}$ )	40 kA
Rated discharge current (8/20 $\mu$ s) ( $I_n$ )	12,5 kA
Maximum discharge current (8/20 $\mu$ s) ( $I_{max}$ )	25 kA
Voltage protection level ( $U_p$ )	$\leq 4$ kV
Maximum working voltage ( $U_c$ )	1000 V

**Electrical parameters (AC)**

Surge protection class	T2 (C)
Rated discharge current (8/20 $\mu$ s) ( $I_n$ )	20 kA
Maximum discharge current (8/20 $\mu$ s) ( $I_{max}$ )	40 kA
Voltage protection level ( $U_p$ )	$\leq 1,5$ kV
Maximum working voltage ( $U_c$ )	275 V
Overcurrent protection	3P B16A iC60

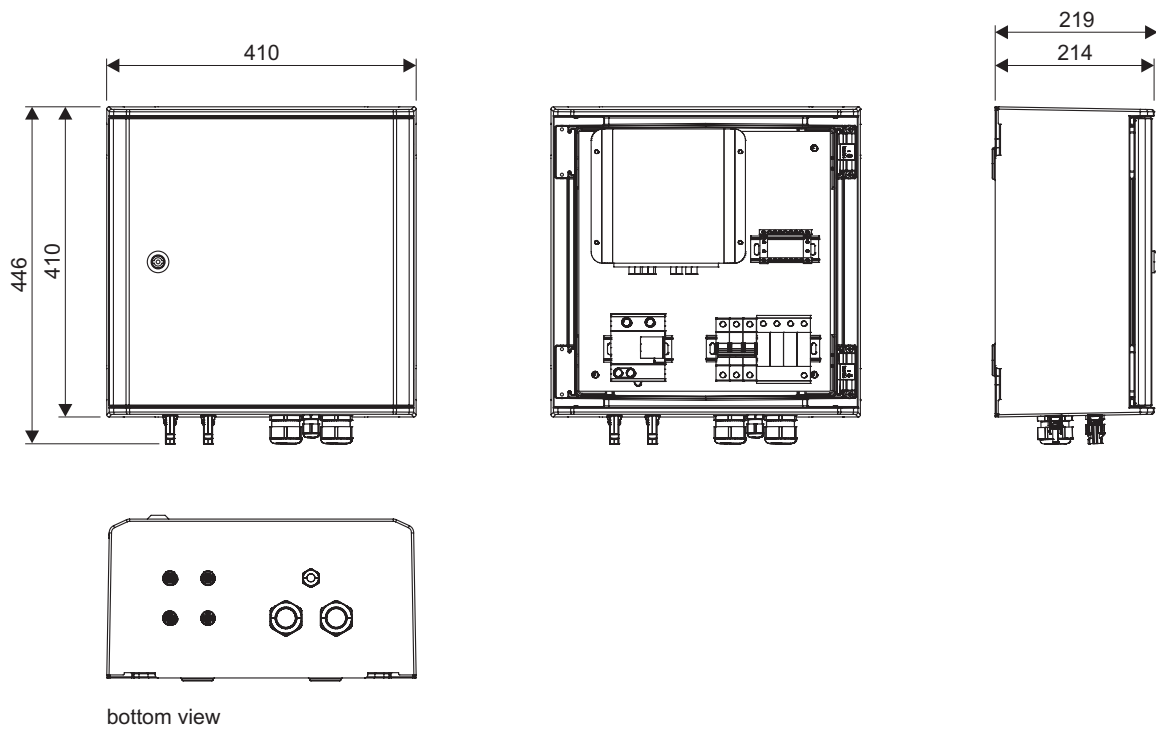

bottom view

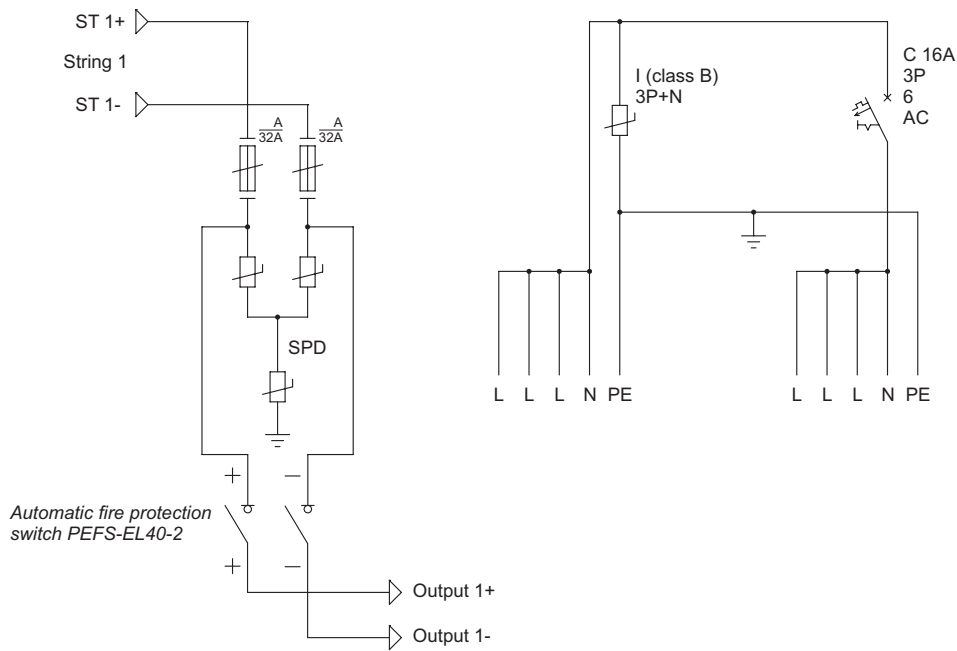

## Technical data

### Installation

Wall mounting	Mount: UMO K3
Post mounting	Mount: UN K3, UPN K3

### Enclosure

Type	HYDRA 445
Isolating material	Glass fiber reinforced polyester
Protection grade IP	IP65
Impact resistance	IK10
Protection class	II
Colour	RAL 7035

### Electrical parameters (DC)

Surge protection class	T2 (C)
Short-circuit resistance (I <sub>SCPV</sub> )	10 kA
Total discharge current (8/20 μs) (I <sub>total</sub> )	40 kA
Rated discharge current (8/20 μs) (I <sub>n</sub> )	20 kA
Maximum discharge current (8/20 μs) (I <sub>max</sub> )	40 kA
Voltage protection level (U <sub>p</sub> )	≤ 4 kV
Maximum working voltage (U <sub>c</sub> )	1170 V
Residual current protection	Fuse base 2P DC 1000V 32A

### Electrical parameters (AC)

Surge protection class	T2 (C)
Rated discharge current (8/20 μs) (I <sub>n</sub> )	20 kA
Maximum discharge current (8/20 μs) (I <sub>max</sub> )	40 kA
Voltage protection level (U <sub>p</sub> )	≤ 1,5 kV
Maximum working voltage (U <sub>c</sub> )	275 V
Overcurrent protection	3P B16A iC60

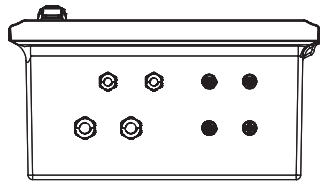
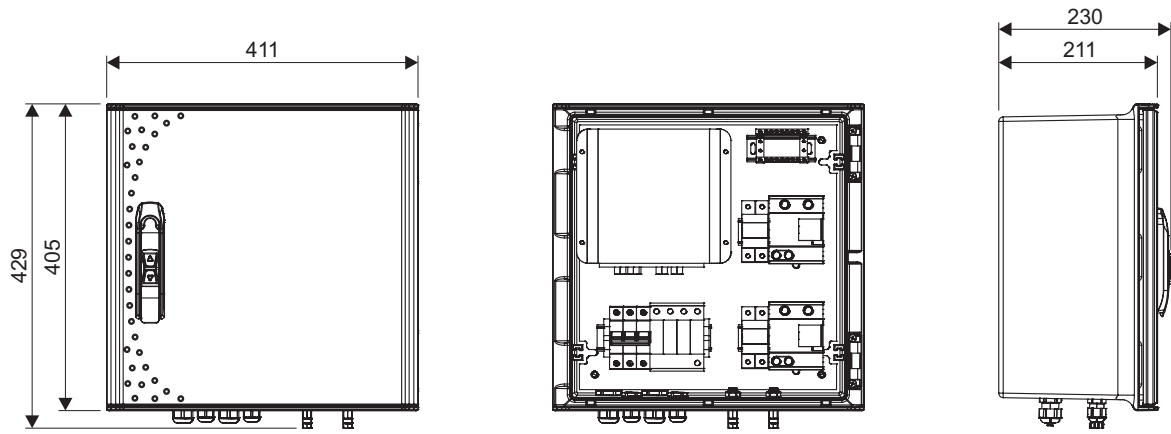

bottom view

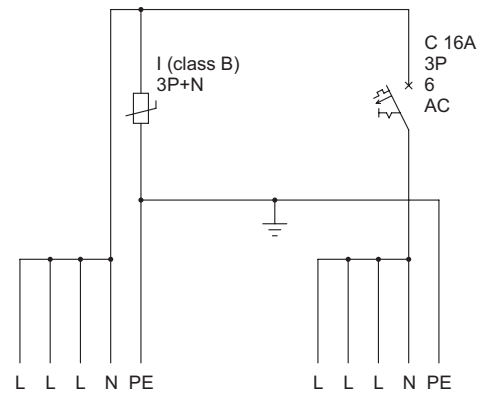
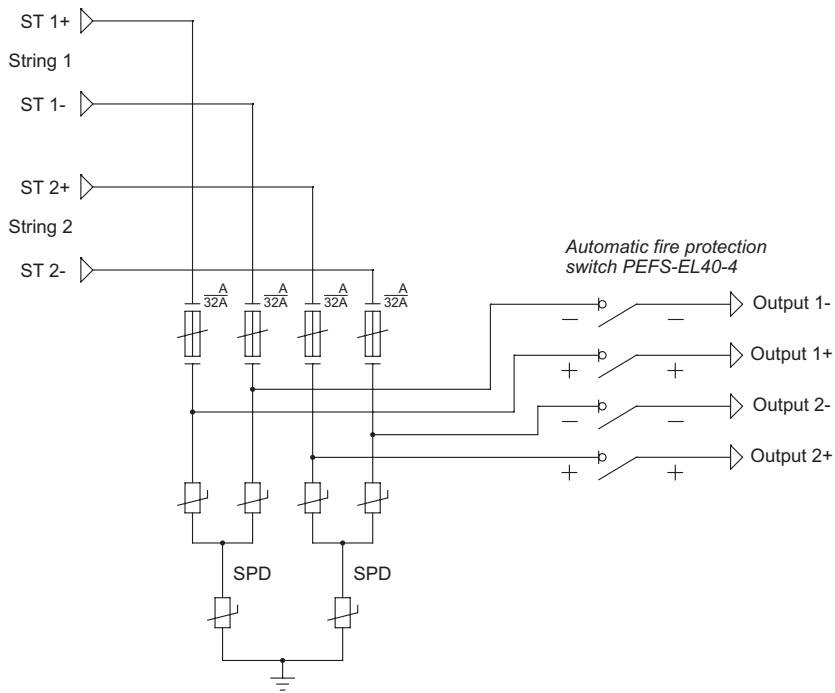

## Technical data

### Installation

Wall mounting	Mount: UMO K3
Post mounting	Mount: UN K3, UPN K3

### Enclosure

Type	LILA 4466
Isolating material	Glass fiber reinforced polyester
Protection grade IP	IP66
Impact resistance	IK10
Protection class	II
Colour	RAL 7035

### Electrical parameters (DC)

Surge protection class	T2 (C)
Short-circuit resistance ( $I_{SCPV}$ )	10 kA
Total discharge current (8/20 $\mu$ s) ( $I_{total}$ )	40 kA
Rated discharge current (8/20 $\mu$ s) ( $I_n$ )	20 kA
Maximum discharge current (8/20 $\mu$ s) ( $I_{max}$ )	40 kA
Voltage protection level ( $U_p$ )	$\leq 4$ kV
Maximum working voltage ( $U_c$ )	1170 V
Residual current protection	Fuse base DC 1000V 32A

### Electrical parameters (AC)

Surge protection class	T2 (C)
Rated discharge current (8/20 $\mu$ s) ( $I_n$ )	20 kA
Maximum discharge current (8/20 $\mu$ s) ( $I_{max}$ )	40 kA
Voltage protection level ( $U_p$ )	$\leq 1,5$ kV
Maximum working voltage ( $U_c$ )	275 V
Overcurrent protection	3P C16A iC60

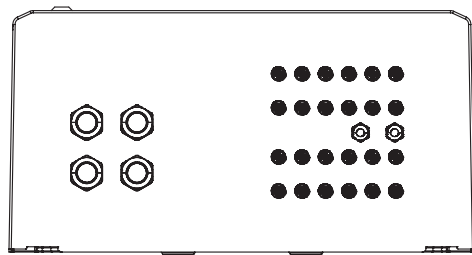
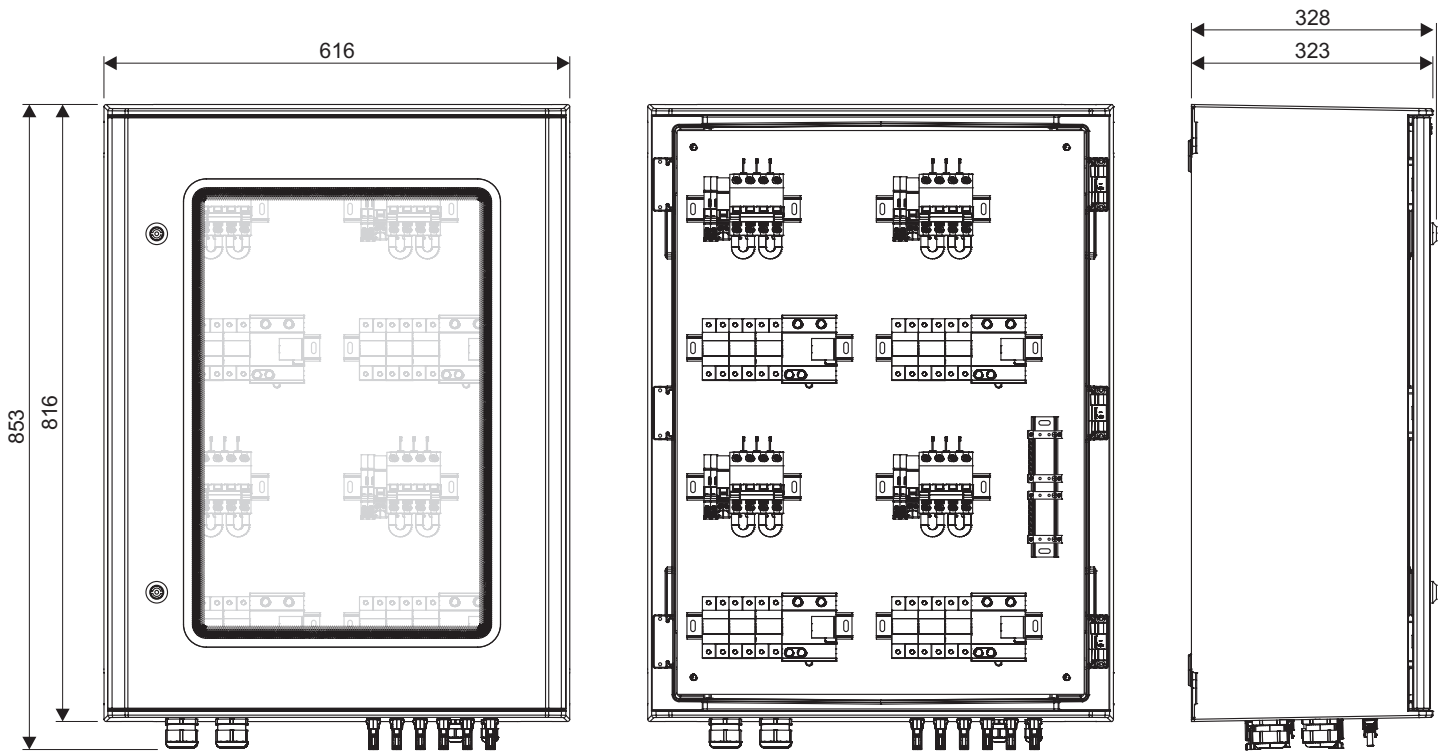

bottom view

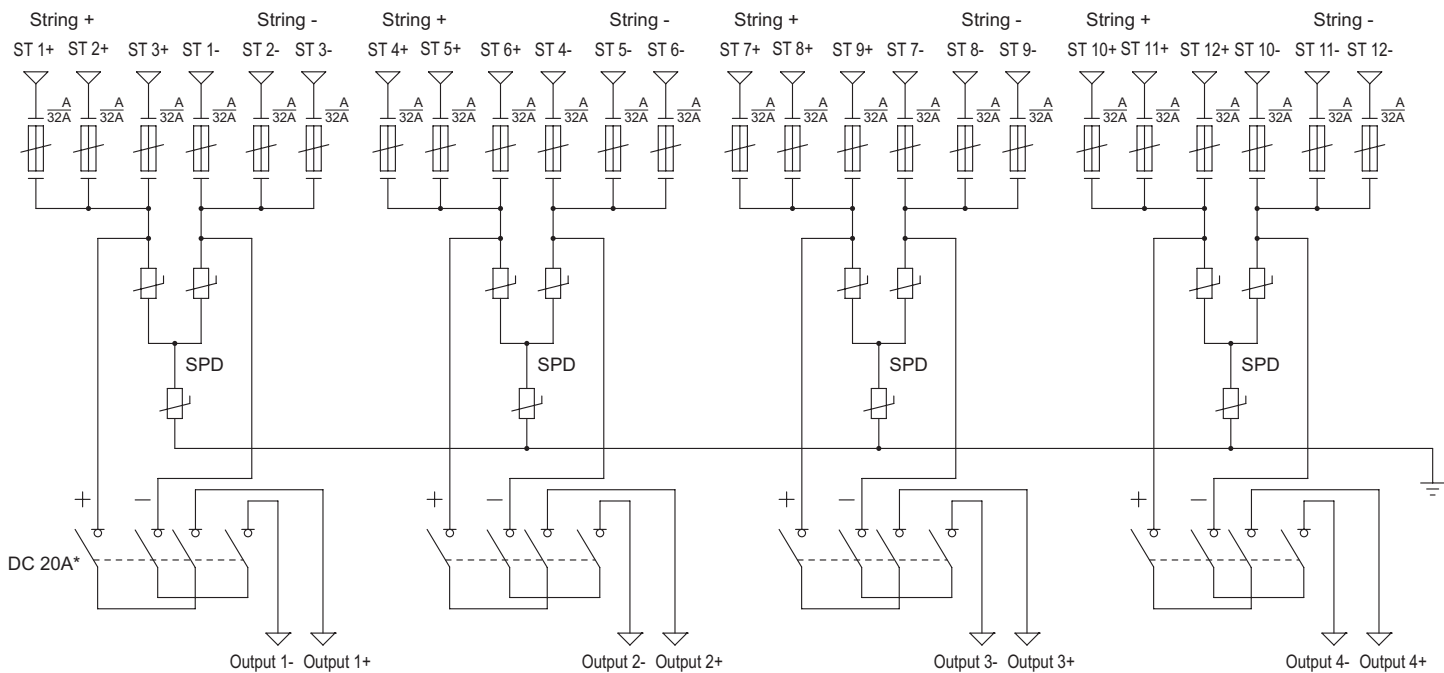

\*) 50A DC switch with undervoltage delayed release and auxiliary contacts 1 NO, 1 NC

## Technical data

### Installation

Wall mounting	Mount UMO K3
Post mounting	Mount UN K3, UPN K3

### Enclosure

Type	HYDRA T 685
Isolating material	Glass fiber reinforced polyester
Protection grade IP	IP65
Impact resistance	IK10
Protection class	II
Colour	RAL 7035

### Electrical parameters (DC)

Surge protection class	T2 (C)
Short-circuit resistance ( $I_{SCP}$ )	10 kA
Total discharge current (8/20 $\mu$ s) ( $I_{total}$ )	40 kA
Rated discharge current (8/20 $\mu$ s) ( $I_n$ )	20 kA
Maximum discharge current (8/20 $\mu$ s) ( $I_{max}$ )	40 kA
Voltage protection level ( $U_p$ )	$\leq 4$ kV
Maximum working voltage ( $U_c$ )	1170 V
Residual current protection	<ul style="list-style-type: none"> <li>• Fuse base 1000V 32A (maximum input current per string: 15A)</li> <li>• Switch disconnecter 1000V 50A</li> </ul>

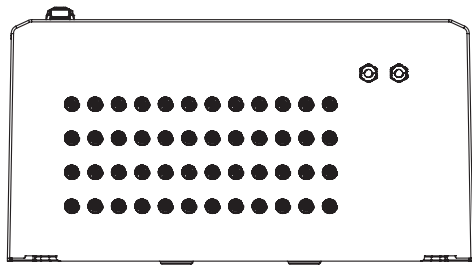
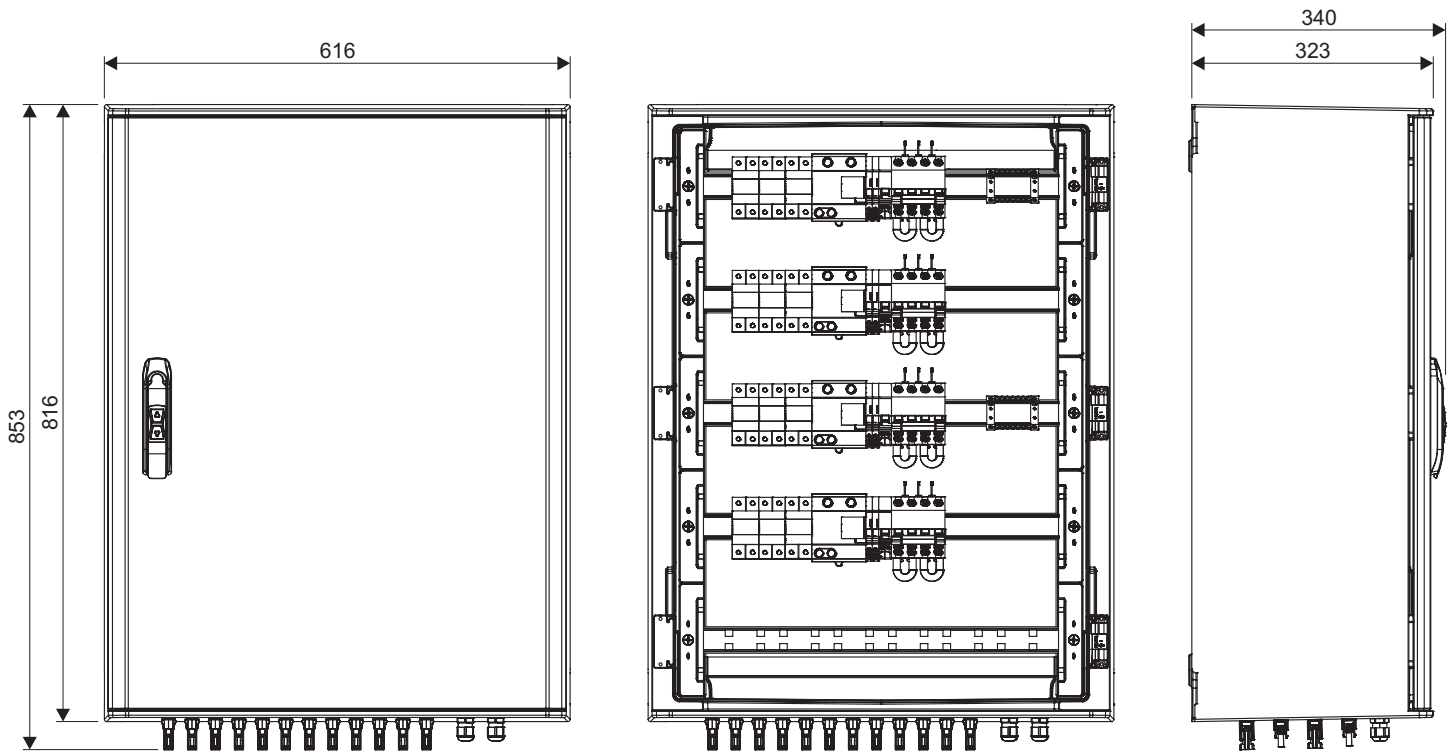

bottom view

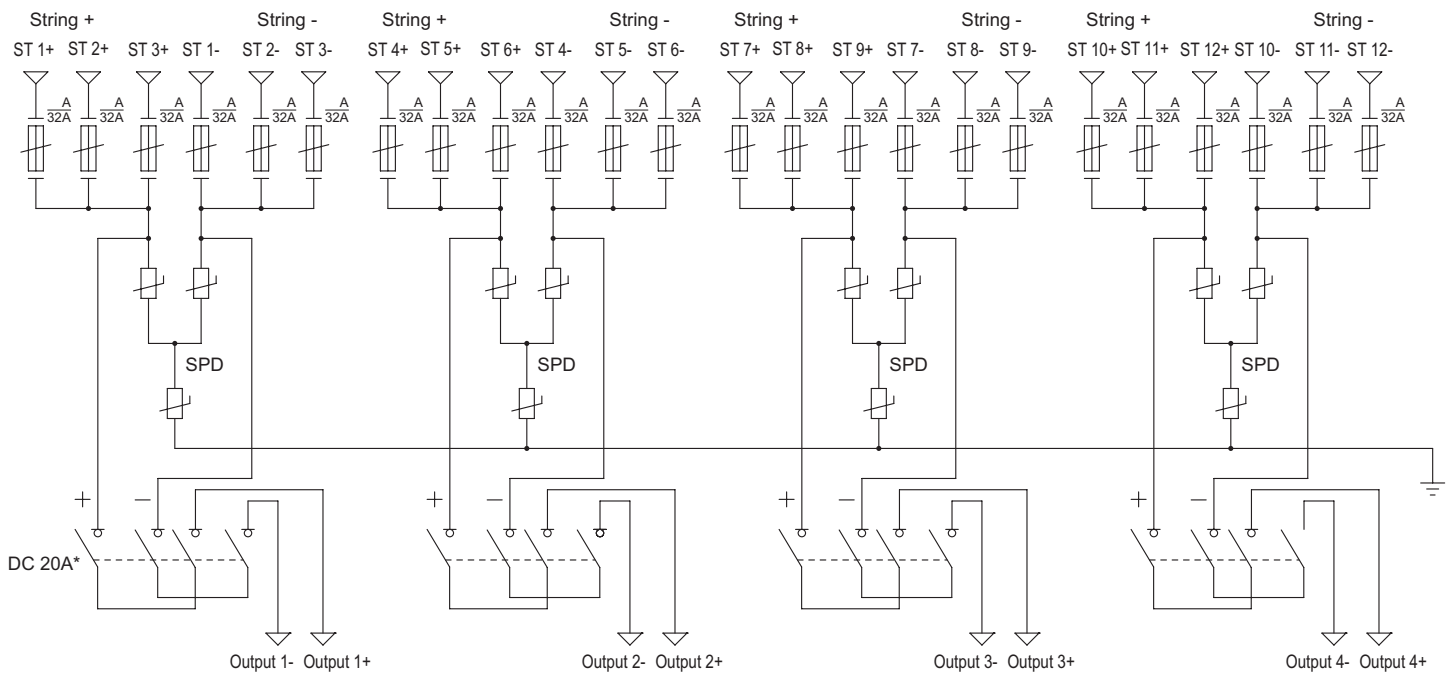

\*) 20A DC switch with undervoltage delayed release and auxiliary contacts 1 NO, 1 NC

## Technical data

### Installation

Wall mounting	Mount: UMO K3
Post mounting	Mount: UN K3, UPN K3

### Enclosure

Type	HYDRA 686
Isolating material	Glass fiber reinforced polyester
Protection grade IP	IP66
Impact resistance	IK10
Protection class	II
Colour	RAL 7035

### Electrical parameters (DC)

Surge protection class	T2 (C)
Short-circuit resistance ( $I_{SCPV}$ )	10 kA
Total discharge current (8/20 $\mu$ s) ( $I_{total}$ )	40 kA
Rated discharge current (8/20 $\mu$ s) ( $I_n$ )	20 kA
Maximum discharge current (8/20 $\mu$ s) ( $I_{max}$ )	40 kA
Voltage protection level ( $U_p$ )	$\leq 4$ kV
Maximum working voltage ( $U_c$ )	1170 V
Residual current protection	<ul style="list-style-type: none"> <li>• Fuse base 1000V 32A (maximum input current per string: 15A)</li> <li>• Switch disconnecter 1000V 50A</li> </ul>

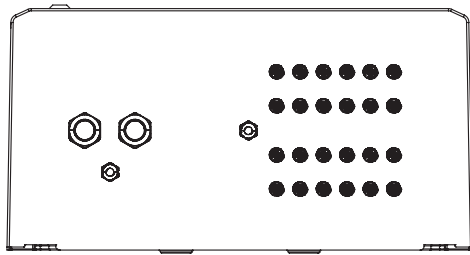
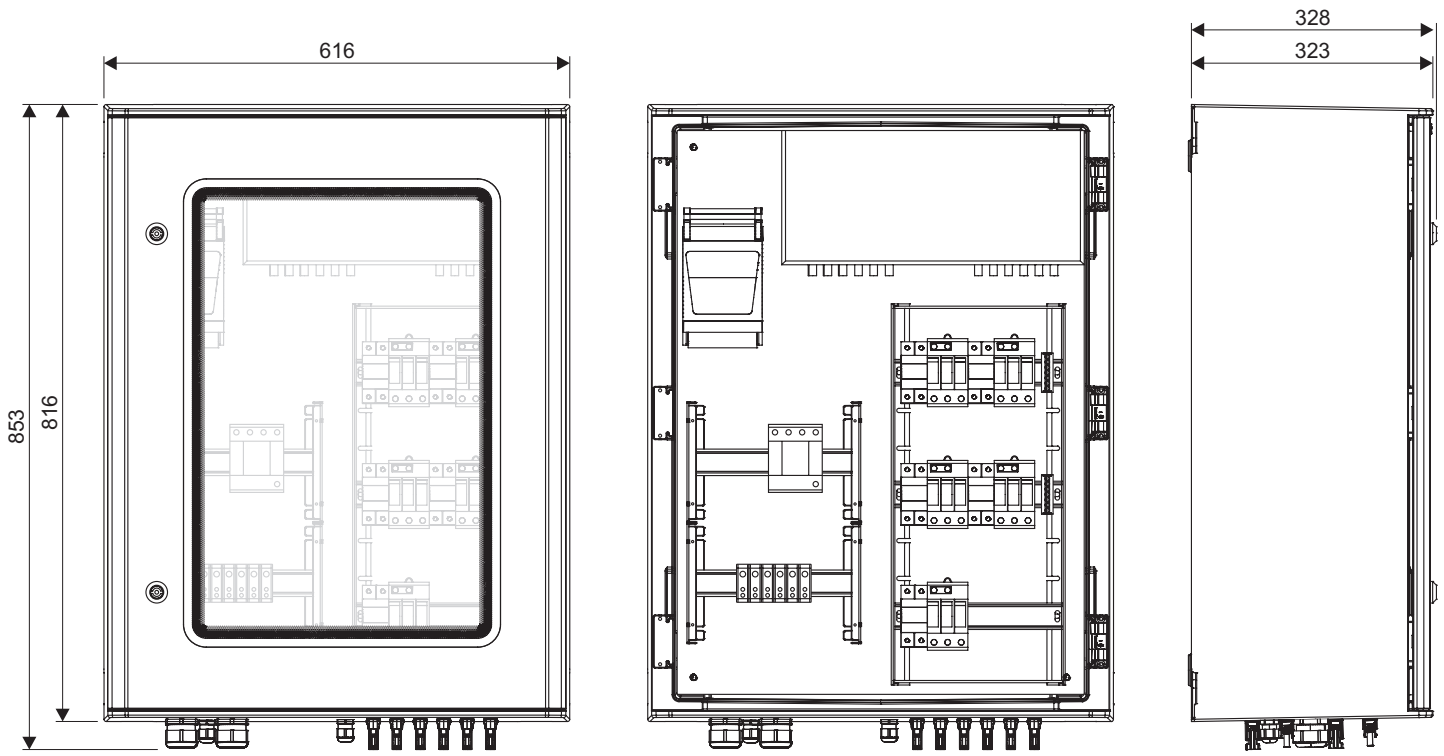

bottom view

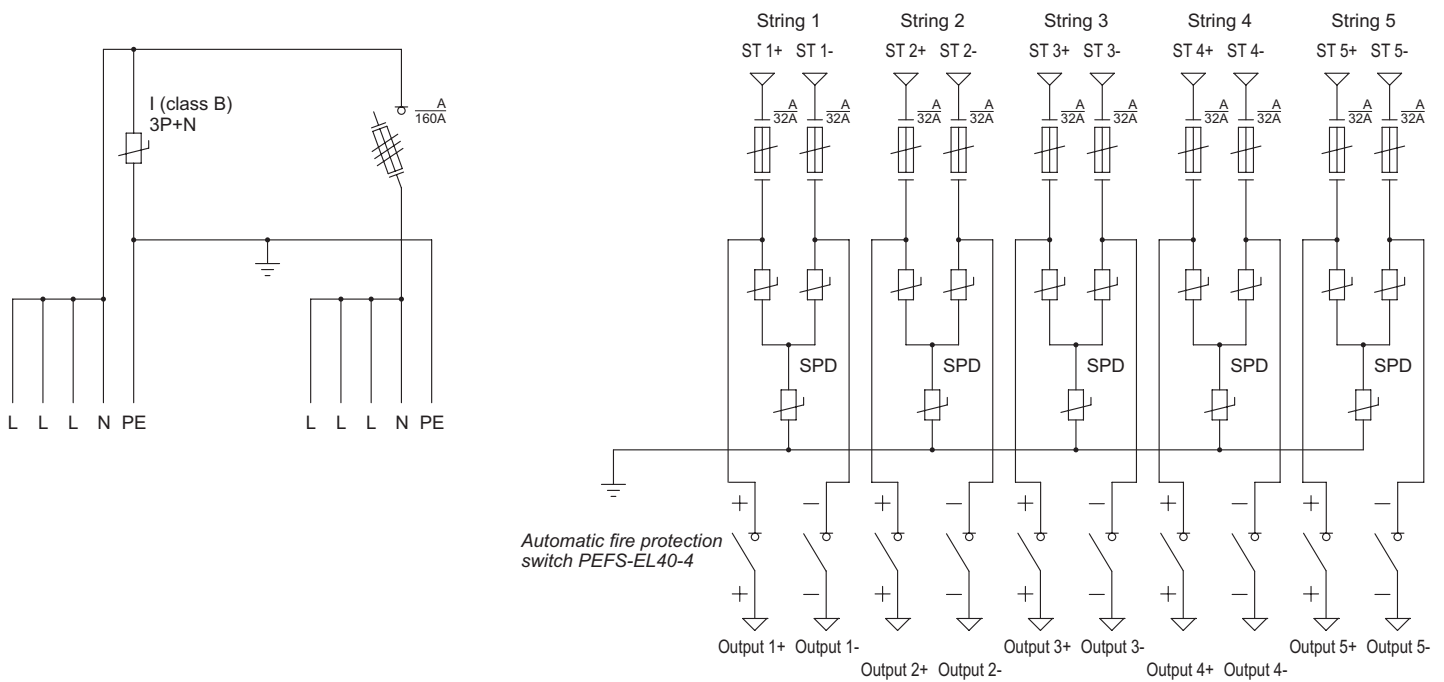

## Technical data

### Installation

Wall mounting	Mount: UMO K3
Post mounting	Mount: UN K3, UPN K3

### Enclosure

Type	HYDRA T 685
Isolating material	Glass fiber reinforced polyester
Protection grade IP	IP65
Impact resistance	IK10
Protection class	II
Colour	RAL 7035

### Electrical parameters (DC)

Surge protection class	T2 (C)
Short-circuit resistance ( $I_{SCP}$ )	10 kA
Total discharge current (8/20 $\mu$ s) ( $I_{total}$ )	40 kA
Rated discharge current (8/20 $\mu$ s) ( $I_n$ )	20 kA
Maximum discharge current (8/20 $\mu$ s) ( $I_{max}$ )	40 kA
Voltage protection level ( $U_p$ )	$\leq 4$ kV
Maximum working voltage ( $U_c$ )	1170 V
Residual current protection	<ul style="list-style-type: none"> <li>• Fuse base 1000V – maximum input current per string: 15A</li> <li>• Switch disconnecter 1000V 50A (5-string) – fire protection disconnecter</li> </ul>

### Electrical parameters (AC)

Surge protection class	T2 (C)
Rated discharge current (8/20 $\mu$ s) ( $I_n$ )	20 kA
Maximum discharge current (8/20 $\mu$ s) ( $I_{max}$ )	40 kA
Voltage protection level ( $U_p$ )	$\leq 1,5$ kV
Maximum working voltage ( $U_c$ )	275 V
Residual current protection	Fuse switch disconnecter 690V 160A

---

ZUP EMITER sp. z o.o.  
ul. Skrudlak 3  
34-600 Limanowa  
18 337 00 90  
emiter@emiter.com  
www.emiter.com